

ON GMD

# L K HOIST

NO	DESCRIPTION	SIZE	MAT' L	Q' TY	WT (kg)	REMARKS

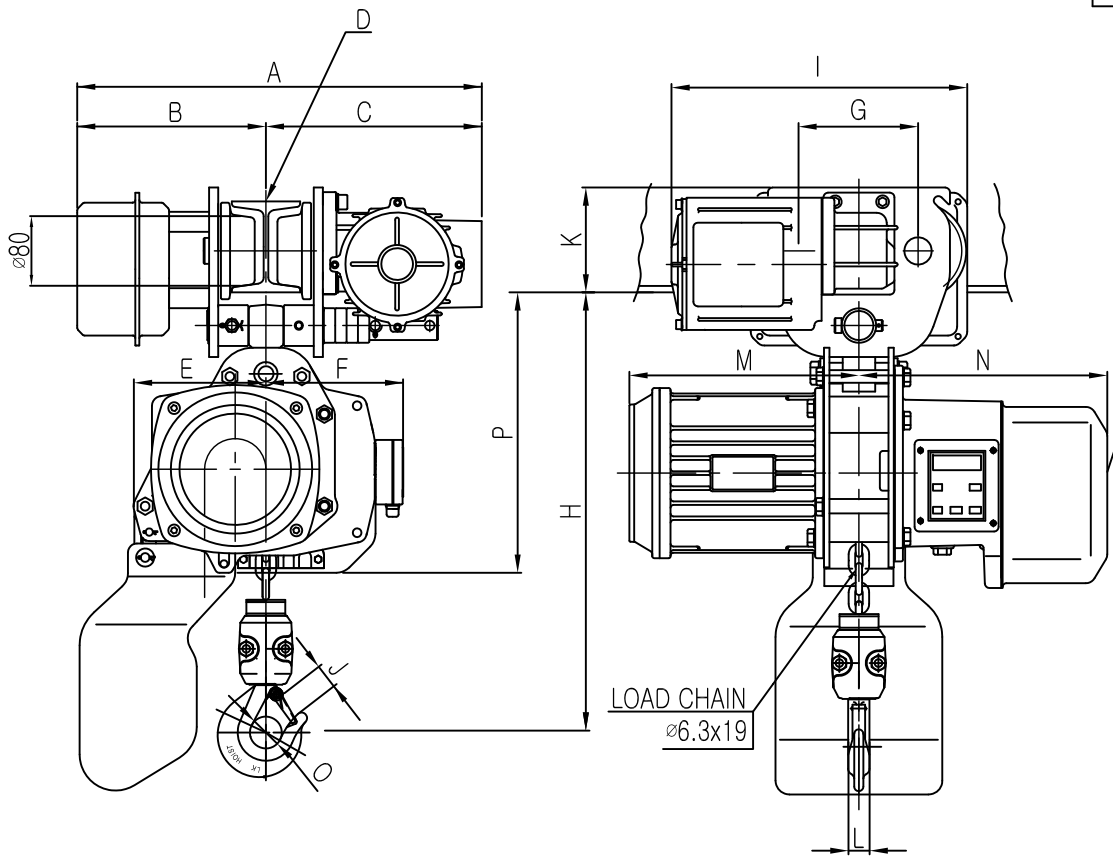

제조일 : 0000-00-00  
 형식번호 : 00-000-00  
 정격하중 : 00-000-00  
 제조자 : (주)LK

## SPECIFICATION

		LTM-0.5S		
RATED LOAD	(TON)	0.5		
TESTING LOAD	(TON)	0.625		
LIFTING HEIGHT	(M)	50		
HOISTING	SPEED (M/MIN)	8		
	MOTOR (KW)	0.8kw x 4p		
TRAVERSING	SPEED (M/MIN)	18.8	9.23	18.8/4.6
	MOTOR (KW)	0.3kw x 2p	0.2kw x 4p	0.3/0.15kw x 2/8p
POWER SUPPLY	AC220.380.440.460.480Vx3ø x 60 Hz			
OPERATING METHOD	P.B type ON . FL			
LOAD CHAIN	ø6.3 X 19(1FALL)			
WEIGHT	(KG)	121		
I-BEAM 적용폭	75 ~ 175MM			

## DIMENSIONS

MODEL	A	B	C	D	E	F	G	H	I	J	K	L	M	N	O	P
LTM-0.5S	449	207	242	75~175	145	191	130	446±19	370	25	110	24	252	273	35	342

- 적용 I-BEAM)
- 1) I- 150 X75 X5.5/9.5 - 3.5M
  - 2) I- 200 X100 X7/10 - 6.0M
  - 3) I- 250 X125 X7.5/12.5 - 8.0M
  - 4) I- 300 X150 X10/18.5 - 11M
  - 5) I- 450 X175 X13/26 - 15M

## NOTE)

- 1)점검 설비를 갖출 것
- 2)인허가 서류를 완성검사시 제출 할 것

REV.NO	DATE	REVISION	DESCRIPTION	DRAWN	CHECKED	APPROVED

TITLE				CHAIN HOIST LTM-0.5S			PROJECTION		
WORK NO				WORK NAME					
DRAWN				CHECKED		REVIEWED		APPROVED	
2010.07.15								DRAWING NO	
김창기								SCALE	
								Q' TY	
								N S 1	

ON GMD

# L K HOIST

NO	DESCRIPTION	SIZE	MAT'L	Q'TY	WT (kg)	REMARKS

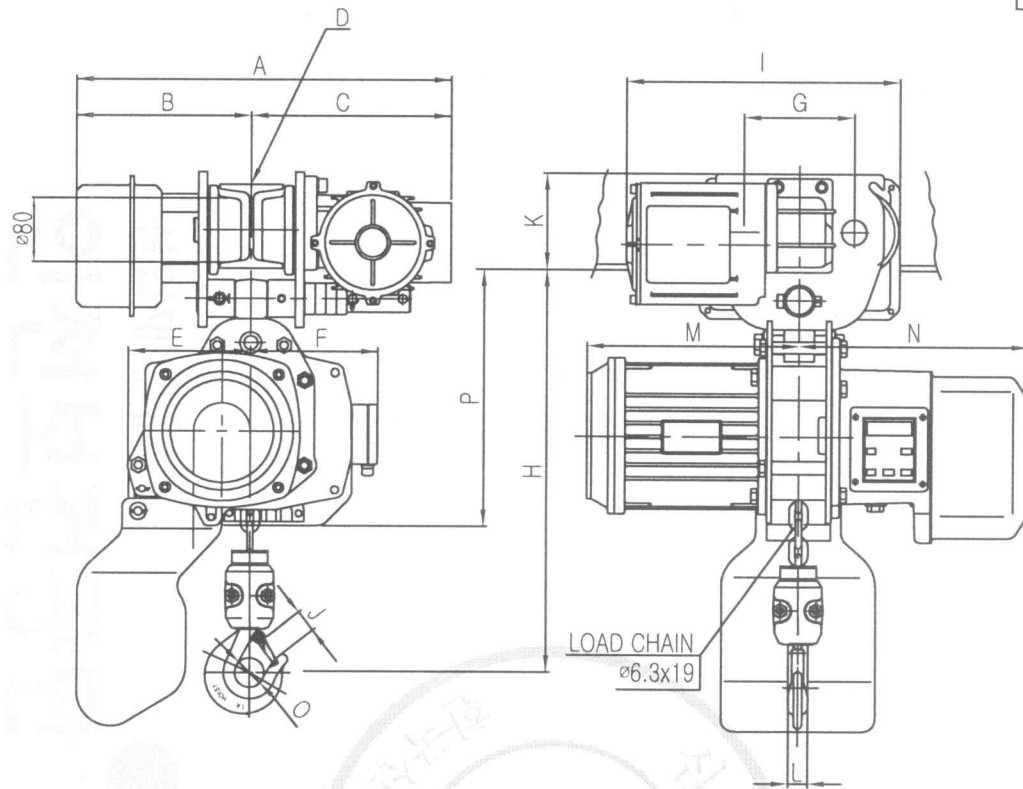

제조일 : 0000-00-00  
 형식번호 : 00-000-00  
 정격하중 : 00-000-00  
 제조자 : (주)LK

## SPECIFICATION

		LTM-0.5S		
RATED LOAD (TON)		0.5		
TESTING LOAD (TON)		0.625		
LIFTING HEIGHT (M)		50		
HOISTING	SPEED (M/MIN)	8		
	MOTOR (KW)	0.8kw x 4p		
TRAVERSING	SPEED (M/MIN)	18.8	9.23	18.8/4.6
	MOTOR (KW)	0.3kw x 2p	0.2kw x 4p	0.3/0.15kw x 2/8p
POWER SUPPLY		AC220.380.440.460.480Vx3φ x 60 Hz		
OPERATING METHOD		P.B type ON . FL		
LOAD CHAIN		φ6.3 X 19(1FALL)		
WEIGHT (KG)		121		
I-BEAM 적용폭		75 ~ 175MM		

## DIMENSIONS

MODEL	A	B	C	D	E	F	G	H	I	J	K	L	M	N	O	P
LTM-0.5S	449	207	242	75~175	145	191	130	446±19	370	25	110	24	252	273	35	342

- 적용 I-BEAM)
- 1) I- 150 X75 X5.5/9.5 - 3.5M
  - 2) I- 200 X100 X7/10 - 6.0M
  - 3) I- 250 X125 X7.5/12.5 - 8.0M
  - 4) I- 300 X150 X10/18.5 - 11M
  - 5) I- 450 X175 X13/26 - 15M

## NOTE)

- 1)점검 설비를 갖춘 것
- 2)인허가 서류를 완성검사시 제출 할 것

REV.NO	DATE	REVISION	DESCRIPTION	DRAWN	CHECKED	APPROVED

TITLE				PROJECTION	
CHAIN HOIST LTM-0.5S					
WORK NO	WORK NAME			SCALE	Q'TY
				N S	1
DRAWN	CHECKED	REVIEWED	APPROVED	DRAWING NO	
김창기					
2010.07.15					

물범복제 및 배포금지