

-NOTE-

1. ----- MARKER OWNER SCOPE
2. 24V인 경우 F21는 3A 적용

SPECIFICATION	NO FUSE BREAKER	MAGNET CONTACT	TRANSFORMER	FUZE
SYMBOLS	MCCB0	MO	TR10	F11, F12, F21
DESCRIPTION	220V	20A	30VA	1A
	380V	10A		
	440V	10A		
	460V	10A		
	480V	10A		
MAKER	LS	LS	DONGA	LK

TITLE MAIN POWER & CONTROL CIRCUIT DIAGRAM						PROJECTION 	
WORK NO 601		WORK NAME LTD				SCALE 1/1	
DRAWN LEE.G.H		CHECKED		REVIEWED		APPROVED	
2010.07.20		DRAWING NO LTD		CODE NO			
L K HOIST CO., LTD.							

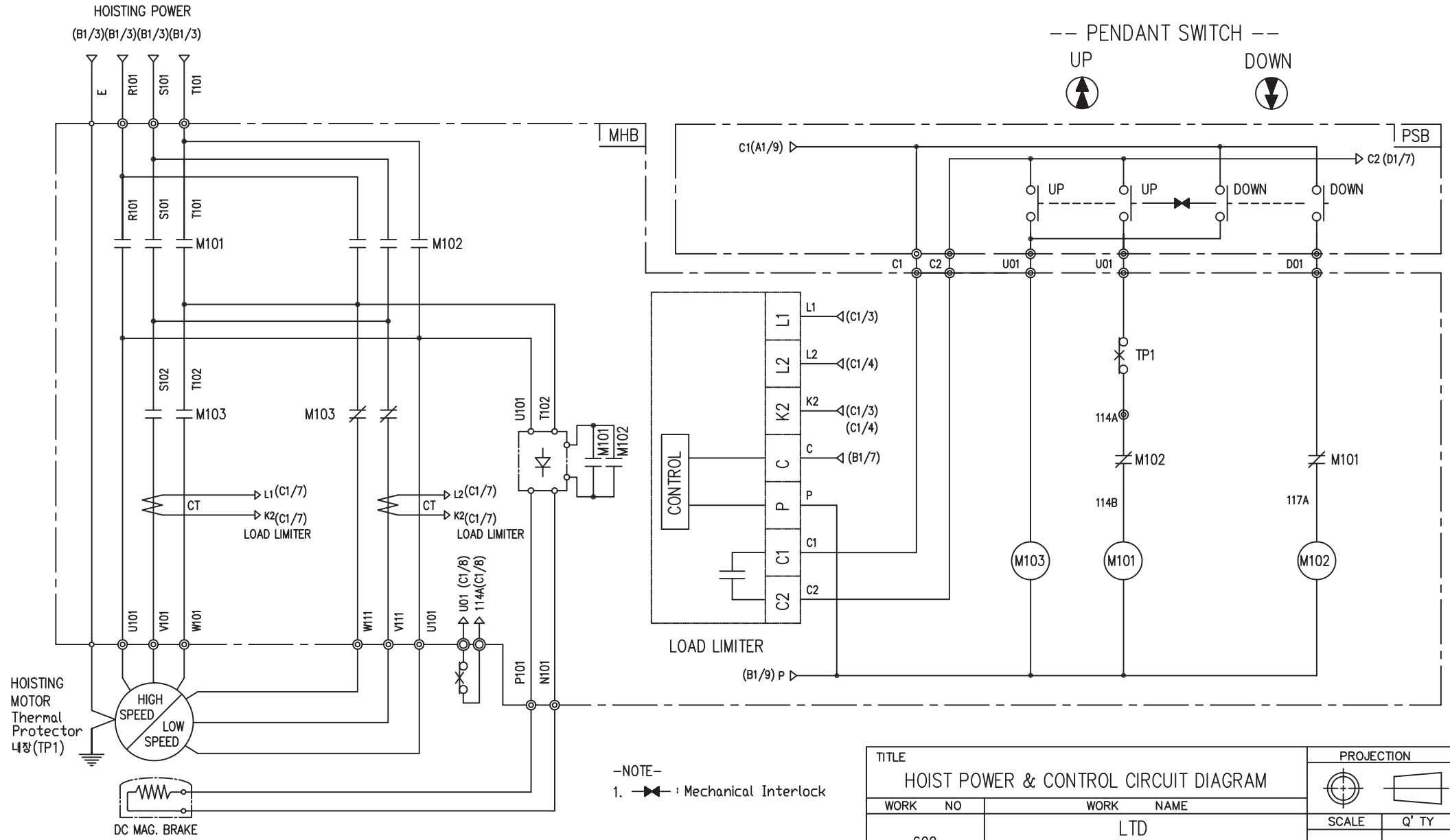

-NOTE-
 1. Mechanical Interlock

TITLE HOIST POWER & CONTROL CIRCUIT DIAGRAM						PROJECTION 	
WORK NO 602		WORK NAME LTD				SCALE 1/1	Q' TY 1
220V, 380V, 440V, 460V, 480V							
DRAWN LEE.G.H	CHECKED	REVIEWED	APPROVED	MODEL	LTD		
2010.07.20				CODE NO			
L K HOIST CO., LTD.							

SPECIFICATION	MAGNET CONTACT		LOAD LIMITER	Thermal Protector	SILICON RECTIFIER					HOIST MOTOR
SYMBOLS	M101, M102, M103		-	TP1	DPM30					HM
DESCRIPTION	GMC12	DMC12	LKDL-501	17AM032	220V	380V	440V	460V	480V	2.0Kw*2P, 0.5Kw*8P
					DC99V	DC171V	DC198V	DC207V	DC216V	
MAKER	LS	DONGA	LK	Texas Instruments	LK					LK

SCHEDULE OF TECHNICAL DATA

1. SERVICE	HOISTING
2. MANUFACTURE	LK HOIST CO. LTD
3. MOTOR MODEL NO	2.0/0.5 - 2/8 - 48
4. RATED POWER	2.0/0.5 KW × 2/8 P
5. RATED VOLTAGE AND FREQUENCY	480 V 60HZ
6. MOTOR TYPE	SQUIRREL CAGE ROTOR TYPE
7. RATING	30 MIN
8. LOCATION	IN-DOOR , OUTDOOR
9. INSULATION CLASS	B
10. DESIGN TEMPERATURE RISE (BY RESISTANCE)	80℃
11. FULL LOAD SPEED	3450 / 850 RPM
12. FULL LOAD CURRENT	4.7/2.12 A
13. STARTING CURRENT AT RATED VOLTAGE	23.5/10.6 A
14. MINIMUM STARTING VOLTAGE	432 V
15. EFFICIENCY AT 100% RATED LOAD	71 / 52 %
16. POWER FACTOR AT 100% RATED LOAD	73 / 52 %
17. STARTING TORQUE	244 / 238 %
18. TYPE OF ENCLOSURE	전폐형
19. TYPE OF BEARING	PL : 6008DD OPL : 6207ZZ
20. MOUNTING	VERTICAL
21. MAXIMUM AMBIENT TEMPURE	40℃
22. BEARING LUBRICATION	GREASE
23. STARTING METHOD	FULL VOLTAGE