

ON ㉔MD

L K HOIST

NO	DESCRIPTION	SIZE	MAT' L	Q' TY	WT (kg)	REMARKS

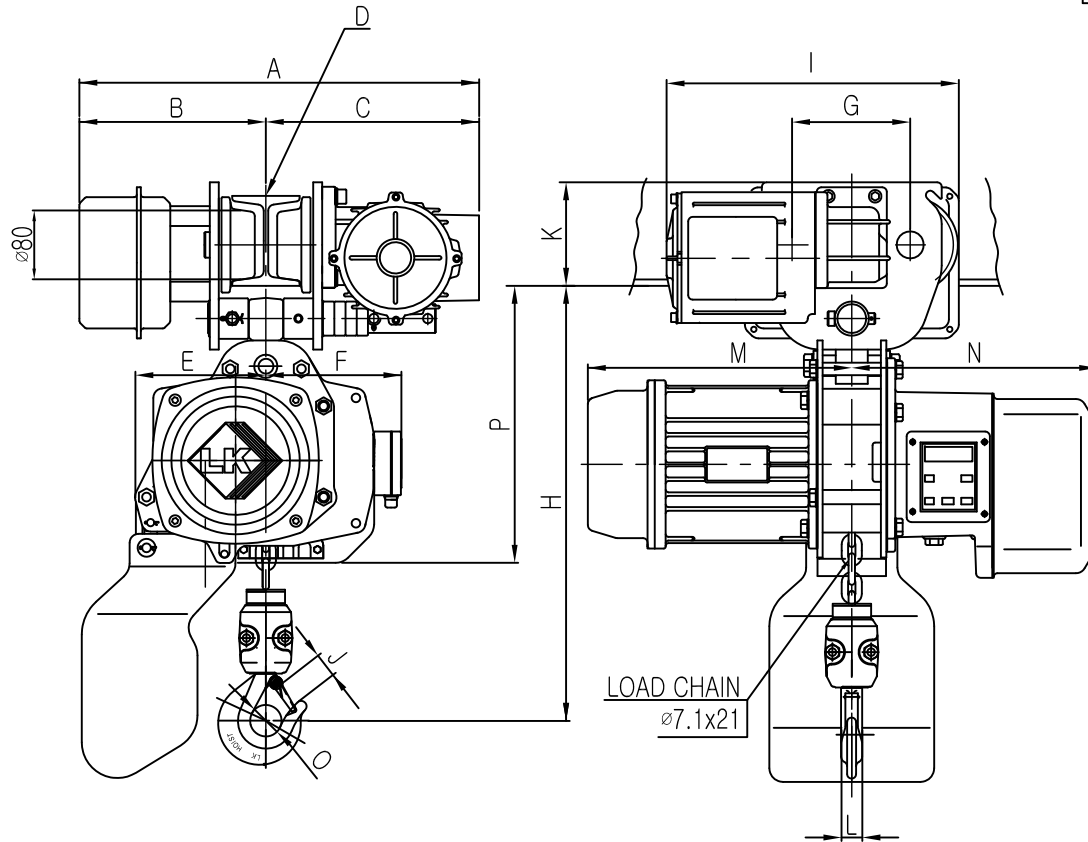

제조일 : 0000-00-00
 형식번호 : 00-000-00
 정격하중 : 00-000-00
 제조자 : (주)LK

SPECIFICATION

		LTDM-1S		
RATED LOAD (TON)		1.0		
TESTING LOAD (TON)		1.25		
LIFTING HEIGHT (M)		50		
HOISTING	SPEED (M/MIN)	8.2/2.0		
	MOTOR (KW)	2.0/0.5kw x 2/8p		
TRAVERSING	SPEED (M/MIN)	18.8	9.23	18.8/4.6
	MOTOR (KW)	0.3kw x 2p	0.2kw x 4p	0.3/0.15kw x 2/8p
POWER SUPPLY		AC220.380.440.460.480Vx3φ x 60 Hz		
OPERATING METHOD		P.B type ON . FL		
LOAD CHAIN		φ7.1 X 21(1FALL)		
WEIGHT (KG)		140		
I-BEAM 적용폭		75 ~ 175MM		

DIMENSIONS

MODEL	A	B	C	D	E	F	G	H	I	J	K	L	M	N	O	P
LTDM-1S	449	207	242	75~175	145	191	130	446±21	370	25	110	24	294	273	35	342

적용 I-BEAM)

- 1) I- 150 X75 X5.5/9.5 - 2.8M
- 2) I- 200 X100 X7/10 - 4.5M
- 3) I- 250 X125 X7.5/12.5 - 6.5M
- 4) I- 300 X150 X10/18.5 - 9.5M
- 5) I- 450 X175 X13/26 - 15M

REV.NO	DATE	REVISION DESCRIPTION	DRAWN	CHECKED	APPROVED

NOTE)

- 1)점검 설비를 갖출 것
- 2)인허가 서류를 완성검사시 제출 할 것

TITLE					PROJECTION	
CHAIN HOIST LTDM-1S						
WORK NO	WORK NAME				SCALE	Q' TY
					N S	1
DRAWN	CHECKED	REVIEWED	APPROVED	DRAWING NO		
김창기						
2010.07.15						

ON OMD

L K HOIST

NO	DESCRIPTION	SIZE	MAT'L	Q'TY	WT (kg)	REMARKS

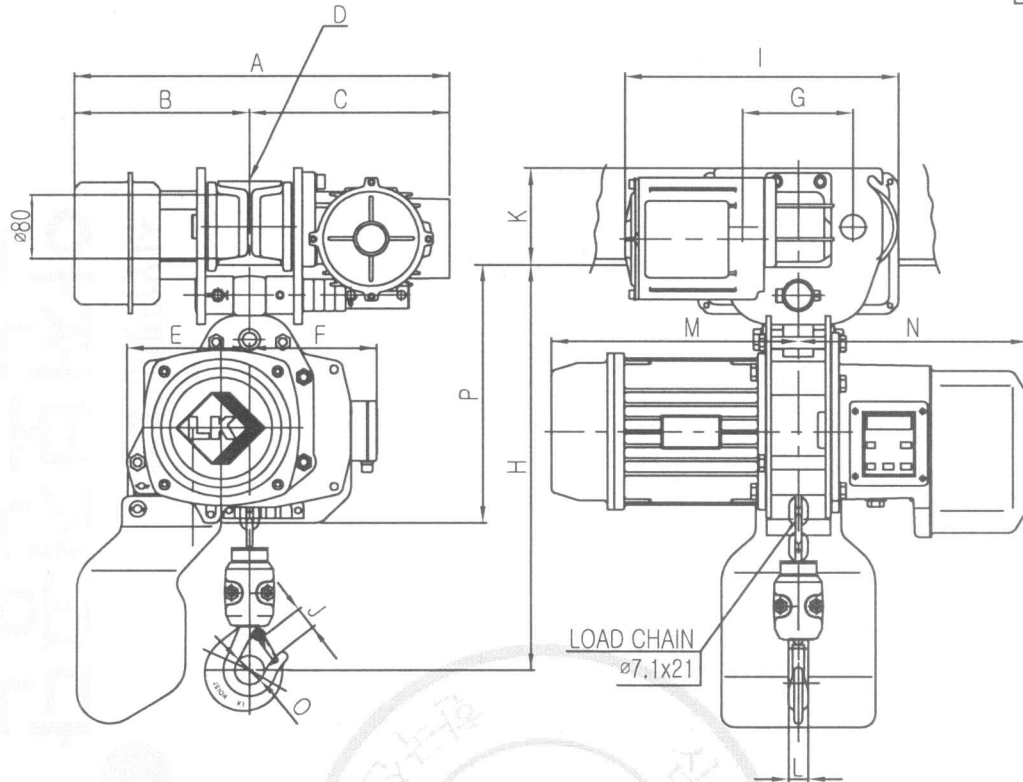

제조일 : 0000-00-00
 형식번호 : 00-000-00
 정격하중 : 00-000-00
 제조자 : (주)LK

SPECIFICATION

		LTDM-1S		
RATED LOAD (TON)		1.0		
TESTING LOAD (TON)		1.25		
LIFTING HEIGHT (M)		50		
HOISTING	SPEED (M/MIN)	8.2/2.0		
	MOTOR (KW)	2.0/0.5kw x 2/8p		
TRAVERSING	SPEED (M/MIN)	18.8	9.23	18.8/4.6
	MOTOR (KW)	0.3kw x 2p	0.2kw x 4p	0.3/0.15kw x 2/8p
POWER SUPPLY		AC220.380.440.460.480Vx3ø x 60 Hz		
OPERATING METHOD		P.B type ON . FL		
LOAD CHAIN		ø7.1 X 21(1FALL)		
WEIGHT (KG)		140		
I-BEAM 적용폭		75 ~ 175MM		

DIMENSIONS

MODEL	A	B	C	D	E	F	G	H	I	J	K	L	M	N	O	P
LTDM-1S	449	207	242	75~175	145	191	130	446±21	370	25	110	24	294	273	35	342

적용 I-BEAM)

- 1) I- 150 X75 X5.5/9.5 - 2.8M
- 2) I- 200 X100 X7/10 - 4.5M
- 3) I- 250 X125 X7.5/12.5 - 6.5M
- 4) I- 300 X150 X10/18.5 - 9.5M
- 5) I- 450 X175 X13/26 - 15M

REV.NO	DATE	REVISION DESCRIPTION	DRAWN	CHECKED	APPROVED

NOTE)

- 1) 점검 설비를 갖출 것
- 2) 인허가 서류를 완성검사시 제출 할 것

TITLE				PROJECTION	
CHAIN HOIST LTDM-1S					
WORK NO	WORK NAME			SCALE	Q' TY
				N S	1
DRAWN	CHECKED	REVIEWED	APPROVED	DRAWING NO	
김창기					
2010.07.15					
L K HOIST CO., LTD.					

문법복제 및 배포금지