

POWER CIRCUIT  
TRAVELLING POWER SUPPLY SYSTEM

ADDRESS NO.  
A1

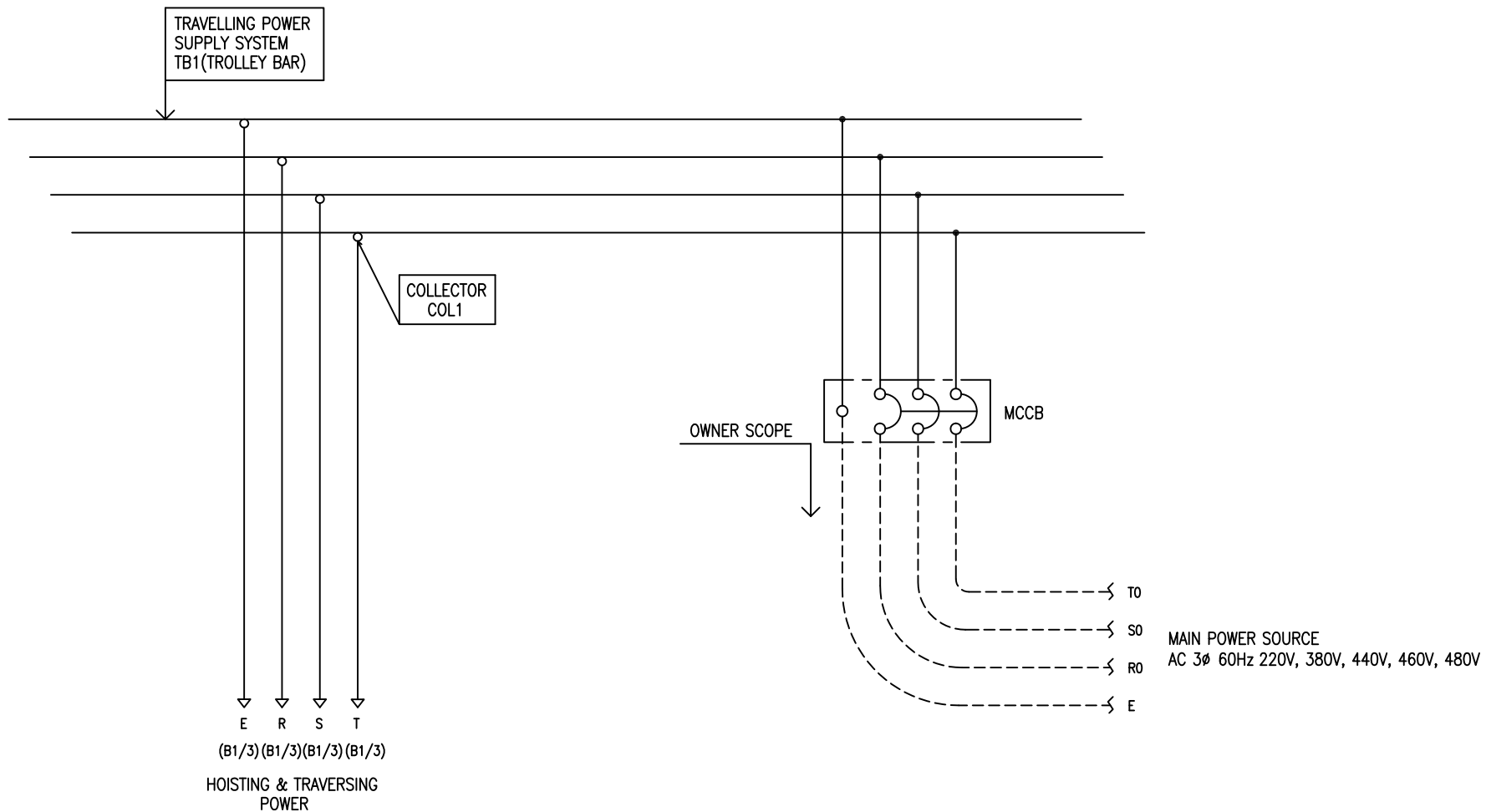

-NOTE-

- 1. - - - - MARKED OWNER SCOPE
- 2. ——— MARKED CRAIN MAKER SCOPE

TITLE MAIN POWER CIRCUIT DIAGRAM1						PROJECTION 	
WORK NO 601		WORK NAME DAM				SCALE 1/1	Q' TY 1
DRAWN LEE G.H. 2012.09.10		CHECKED	REVIEWED	APPROVED	DRAWING NO DAM	CODE NO	
L K HOIST CO., LTD.							

POWER CIRCUIT

CONTROL CIRCUIT

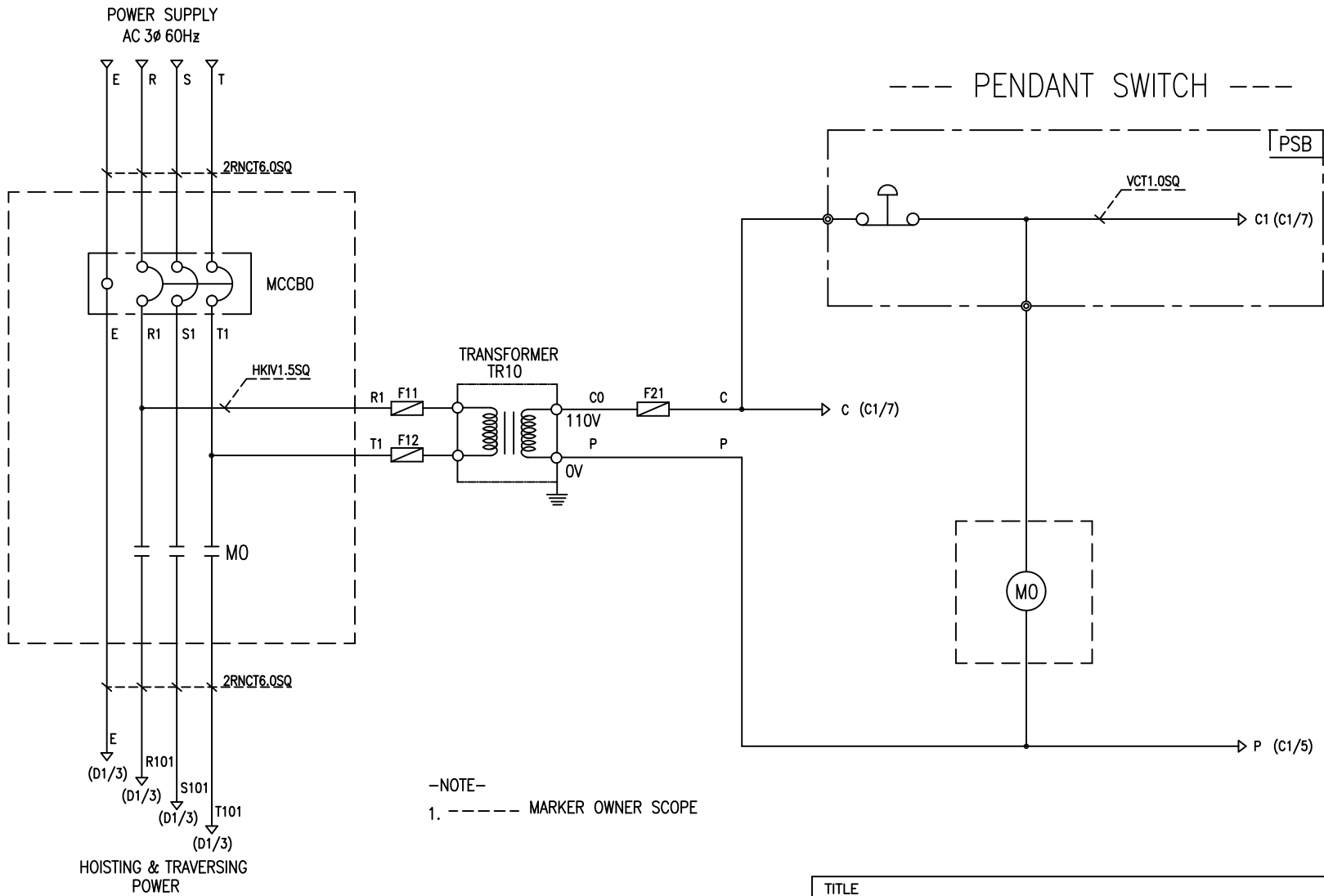

-NOTE-  
1. ----- MARKER OWNER SCOPE

SPECIFICATION	NO FUSE BREAKER	MAGNET CONTACT	TRANSFORMER	FUSE		
SYMBOLS	MCCBO	MO	TR10	F11, F12, F21		
DESCRIPTION	220V	50A	GMC22	DMC-22	40VA	1A
	380V	30A				
	440V	20A				
	460V	20A				
	480V	20A				
MAKER	LS	LS	DONGA	LK	-	

TITLE						PROJECTION	
MAIN POWER & CONTROL CIRCUIT DIAGRAM							
WORK NO	WORK NAME					SCALE	Q' TY
602	DAM					1/1	1
220V, 380V, 440V, 460V, 480V							
DRAWN	CHECKED	REVIEWED	APPROVED	MODEL	DAM		
LEE.G.H				CODE NO			
2012.09.10							

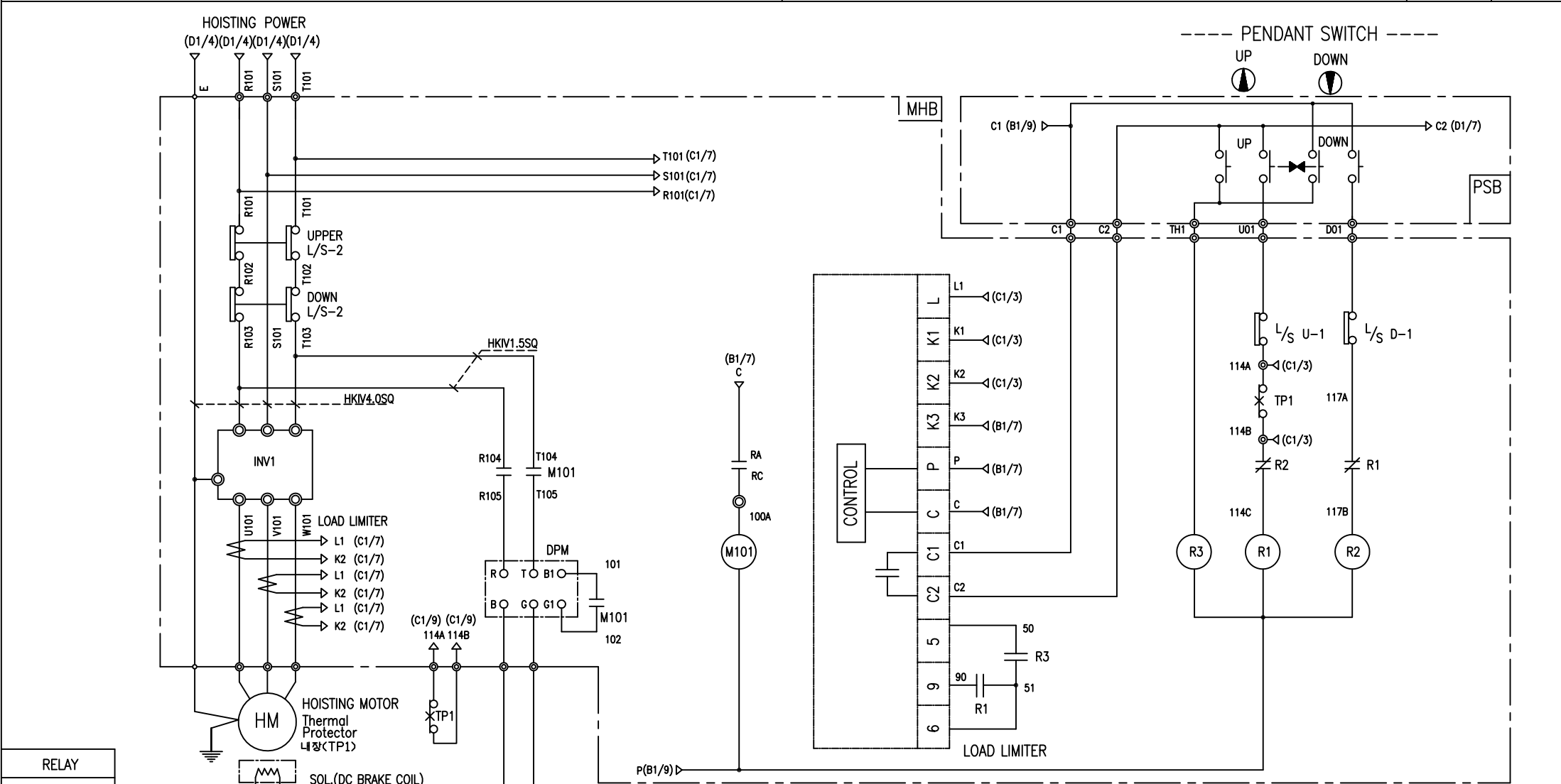

-NOTE-  
 1. : Mechanical Interlock

RELAY
R1, R2, R3
4A4B
KACON
SPECIFICATION
SYMBOLS
DESCRIPTION
MAKER

MAGNET CONTACT	LOAD LIMITER	SILICON RECTIFIER					Thermal Protector	HOIST MOTOR	
M101	-	DPM					TP1	HM	
DESCRIPTION	DMC25C	ALD-90 INV	AC220V	AC380V	AC440V	AC460V	AC480V	17AM032	3.5Kw * 4P
MAKER	DONG-A	ASAN	DC99V	DC171V	DC198V	DC207V	DC216V		

TITLE HOIST POWER & CONTROL CIRCUIT DIAGRAM						PROJECTION 	
WORK NO 603		WORK NAME DAM				SCALE 1/1	Q' TY 1
220V, 380V, 440V, 460V, 480V							
DRAWN LEE.G.H	CHECKED	REVIEWED	APPROVED	MODEL DAM	CODE NO		
2012.09.10							
L K HOIST CO., LTD.							

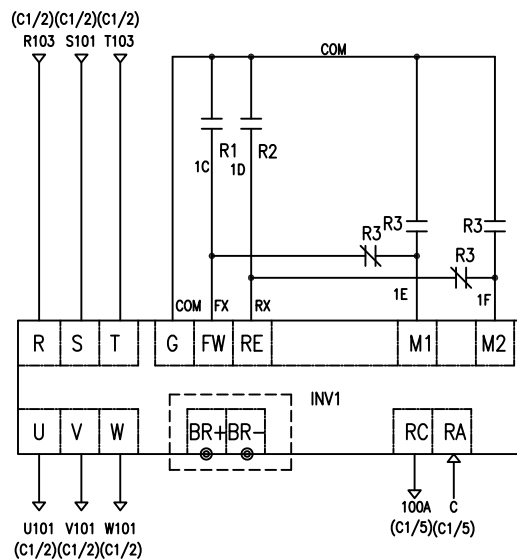

—NOTE—

1. ----- : OPTION SCOPE

SPECIFICATION	INVERTER	BRAKING RESISTOR
SYMBOLS	INV1	BR
DESCRIPTION	3.7KW	400W 150 OHM
MAKER	ROCKWELL	-

TITLE						(D1/6) PROJECTION	
INVERTER CONTROL CIRCUIT DIAGRAM							
WORK NO.	WORK NAME					SCALE	Q' TY
604	HOISTING					1/1	1
220V, 380V, 440V, 460V, 480V							
DRAWN	CHECKED	REVIEWED	APPROVED	MODEL	DAM		
LEE.G.H							
2012.09.10				CODE NO			

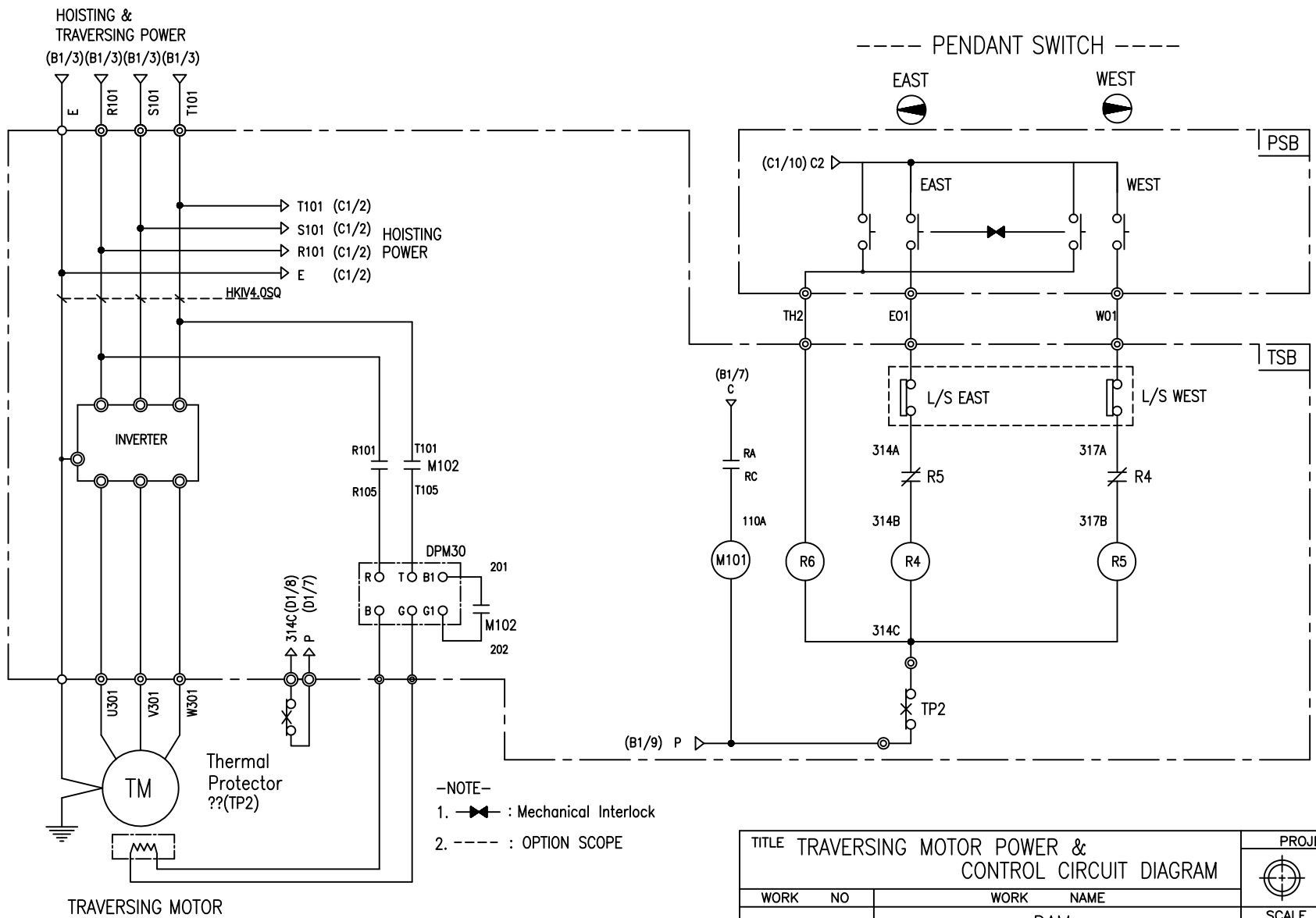

RELAY
R4, R5, R6
4A4B
KACON

SPECIFICATION	MAGNET CONTACT	SILICON RECTIFIER				Thermal Protector	TRAVERSING MOTOR	
SYMBOLS	M102	DPM30				TP2	TM	
DESCRIPTION	DMC12	AC220V	AC380V	AC440V	AC460V	17AM032	0.75KW *4P	0.4KW *6P
		DC99V	DC171V	DC198V	DC207V			
MAKER	DONG-A	LK				Texas Instruments	LK	

TITLE TRAVERSING MOTOR POWER & CONTROL CIRCUIT DIAGRAM						PROJECTION	
WORK NO		WORK NAME					
605		DAM				SCALE	Q' TY
		220V, 380V, 440V, 460V, 480V				1/1	1
DRAWN	CHECKED	REVIEWED	APPROVED	MODEL	DAM		
LEE.G.H				CODE NO			
2012.09.10							
<b>L K HOIST CO., LTD.</b>							

## HOIST CONTROL CIRCUIT

ADDRESS NO.

D2

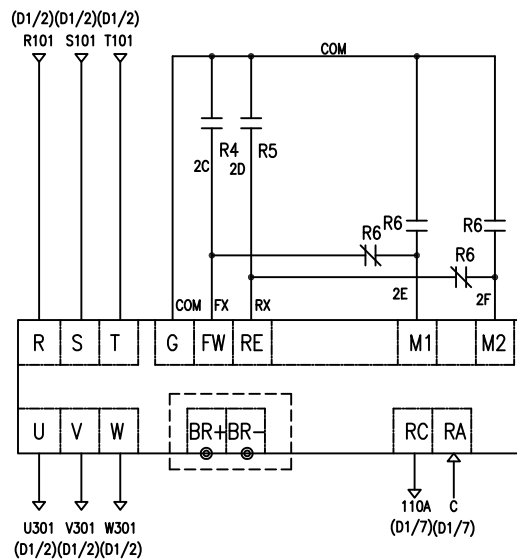

-NOTE-

1. ----- : OPTION SCOPE

SPECIFICATION	INVERTER	BRAKING RESISTOR
SYMBOLS	INV2	BR
DESCRIPTION	0.75KW	80W 750 OHM
MAKER	ROCKWELL	-

TITLE				(D1/6) PROJECTION	
INVERTER CONTROL CIRCUIT DIAGRAM					
WORK NO.	WORK NAME			SCALE	Q' TY
606	TRAVERSING			1/1	1
220V, 380V, 440V, 460V, 480V					
DRAWN	CHECKED	REVIEWED	APPROVED	MODEL	DAM
LEE.G.H				CODE NO	
2012.09.10					

## SCHEDULE OF TECHNICAL DATA

1. SERVICE	HOISTING
2. MANUFACTURE	LK HOIST CO. LTD
3. MOTOR MODEL NO	3.5 - 4 - 44
4. RATED POWER	3.5 KW × 4 P
5. RATED VOLTAGE AND FREQUENCY	440 V      60HZ
6. MOTOR TYPE	SQUIRREL CAGE ROTOR TYPE
7. RATING	30 MIN
8. LOCATION	IN-DOOR , OUTDOOR
9. INSULATION CLASS	B
10. DESIGN TEMPERATURE RISE (BY RESISTANCE)	80℃
11. FULL LOAD SPEED	1740 RPM
12. FULL LOAD CURRENT	8.6 A
13. STARTING CURRENT AT RATED VOLTAGE	46.4 A
14. MINIMUM STARTING VOLTAGE	396 V
15. EFFICIENCY AT 100% RATED LOAD	73.3 %
16. POWER FACTOR AT 100% RATED LOAD	72.8 %
17. STARTING TORQUE	245 %
18. TYPE OF ENCLOSURE	전폐형(IP-54)
19. TYPE OF BEARING	PL : 6205DD    OPL : 6008ZZ
20. MOUNTING	VERTICAL
21. MAXIMUM AMBIENT TEMPURE	40℃
22. BEARING LUBRICATION	GREASE
23. STARTING METHOD	FULL VOLTAGE

## SCHEDULE OF TECHNICAL DATA

1. SERVICE	TRAVERSING
2. MANUFACTURE	LK HOIST CO. LTD
3. MOTOR MODEL NO	0.75 - 4 - 44
4. RATED POWER	0.75 KW × 4 P
5. RATED VOLTAGE AND FREQUENCY	440 V      60HZ
6. MOTOR TYPE	SQUIRREL CAGE ROTOR TYPE
7. RATING	15 MIN
8. LOCATION	OUTDOOR
9. INSULATION CLASS	B
10. DESIGN TEMPERATURE RISE (BY RESISTANCE)	100℃
11. FULL LOAD SPEED	1670 RPM
12. FULL LOAD CURRENT	2.4 A
13. STARTING CURRENT AT RATED VOLTAGE	13.2 A
14. MINIMUM STARTING VOLTAGE	396 V
15. EFFICIENCY AT 100% RATED LOAD	65 %
16. POWER FACTOR AT 100% RATED LOAD	63 %
17. STARTING TORQUE	249 %
18. TYPE OF ENCLOSURE	전폐형
19. TYPE OF BEARING	PL : 6008DD    OPL : 6207ZZ
20. MOUNTING	VERTICAL
21. MAXIMUM AMBIENT TEMPURE	40℃
22. BEARING LUBRICATION	GREASE
23. STARTING METHOD	FULL VOLTAGE

## SCHEDULE OF TECHNICAL DATA

1. SERVICE	TRAVERSING
2. MANUFACTURE	LK HOIST CO. LTD
3. MOTOR MODEL NO	0.4 - 6 - 44
4. RATED POWER	0.4 KW × 6 P
5. RATED VOLTAGE AND FREQUENCY	440 V      60HZ
6. ROTOR TYPE	SQUIRREL CAGE ROTOR TYPE
7. RATING	15 MIN
8. LOCATION	OUTDOOR
9. INSULATION CLASS	B
10. DESIGN TEMPERATURE RISE (BY RESISTANCE)	100℃
11. FULL LOAD SPEED	1140 RPM
12. FULL LOAD CURRENT	1.6 A
13. STARTING CURRENT AT RATED VOLTAGE	8.8 A
14. MINIMUM STARTING VOLTAGE	396 V
15. EFFICIENCY AT 100% RATED LOAD	65 %
16. POWER FACTOR AT 100% RATED LOAD	63 %
17. STARTING TORQUE	250 %
18. TYPE OF ENCLOSURE	전폐형
19. TYPE OF BEARING	PL : 6008DD    OPL : 6207ZZ
20. MOUNTING	VERTICAL
21. MAXIMUM AMBIENT TEMPERATURE	40℃
22. BEARING LUBRICATION	GREASE
23. STARTING METHOD	FULL VOLTAGE

## SCHEDULE OF TECHNICAL DATA

1. SERVICE	TRAVERSING
2. MANUFACTURE	LK HOIST CO. LTD
3. MOTOR MODEL NO	0.75/0.25 - 4/12 - 44
4. RATED POWER	0.75/0.25 KW × 4/12 P
5. RATED VOLTAGE AND FREQUENCY	440 V      60HZ
6. MOTOR TYPE	SQUIRREL CAGE ROTOR TYPE
7. RATING	15 MIN
8. LOCATION	OUTDOOR
9. INSULATION CLASS	B
10. DESIGN TEMPERATURE RISE (BY RESISTANCE)	100℃
11. FULL LOAD SPEED	1670 / 550 RPM
12. FULL LOAD CURRENT	2.4 / 1.5 A
13. STARTING CURRENT AT RATED VOLTAGE	13.2 / 8.25 A
14. MINIMUM STARTING VOLTAGE	396 V
15. EFFICIENCY AT 100% RATED LOAD	65 / 48 %
16. POWER FACTOR AT 100% RATED LOAD	63 / 46 %
17. STARTING TORQUE	250 / 243 %
18. TYPE OF ENCLOSURE	전폐형
19. TYPE OF BEARING	PL : 6008DD    OPL : 6207ZZ
20. MOUNTING	VERTICAL
21. MAXIMUM AMBIENT TEMPURE	40℃
22. BEARING LUBRICATION	GREASE
23. STARTING METHOD	FULL VOLTAGE