

POWER CIRCUIT
TRAVELLING POWER SUPPLY SYSTEM

ADDRESS NO.
A1

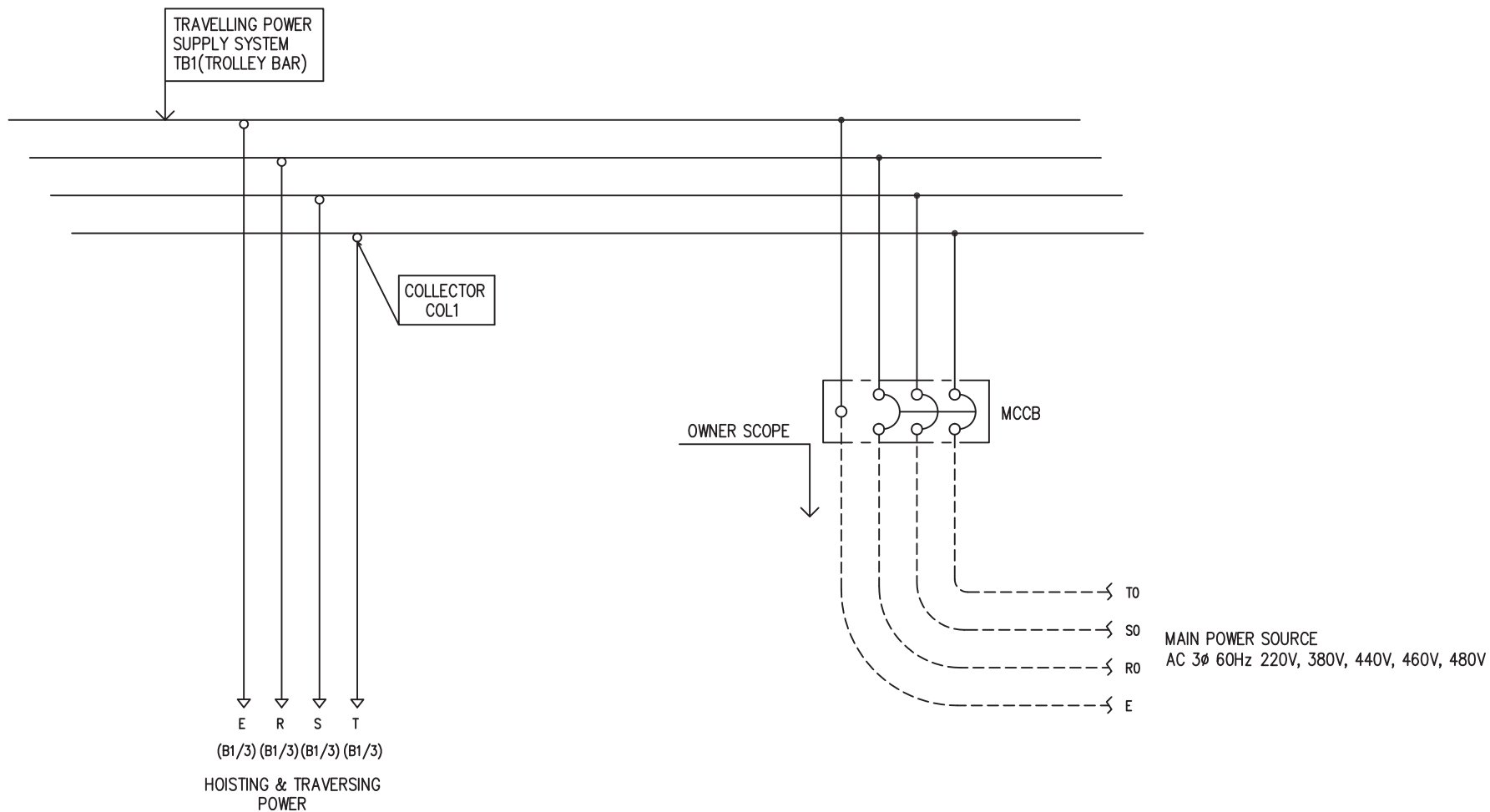

-NOTE-

- 1. - - - - MARKED OWNER SCOPE
- 2. ——— MARKED CRANEMAKER SCOPE

TITLE MAIN POWER CIRCUIT DIAGRAM1				PROJECTION 	
WORK NO 601	WORK NAME LTDM			SCALE 1/1	Q' TY 1
220V, 380V, 440V, 460V, 480V					
DRAWN LEE G.H. 2010.07.20	CHECKED	REVIEWED	APPROVED	DRAWING NO LTDM	CODE NO
L K HOIST CO., LTD.					

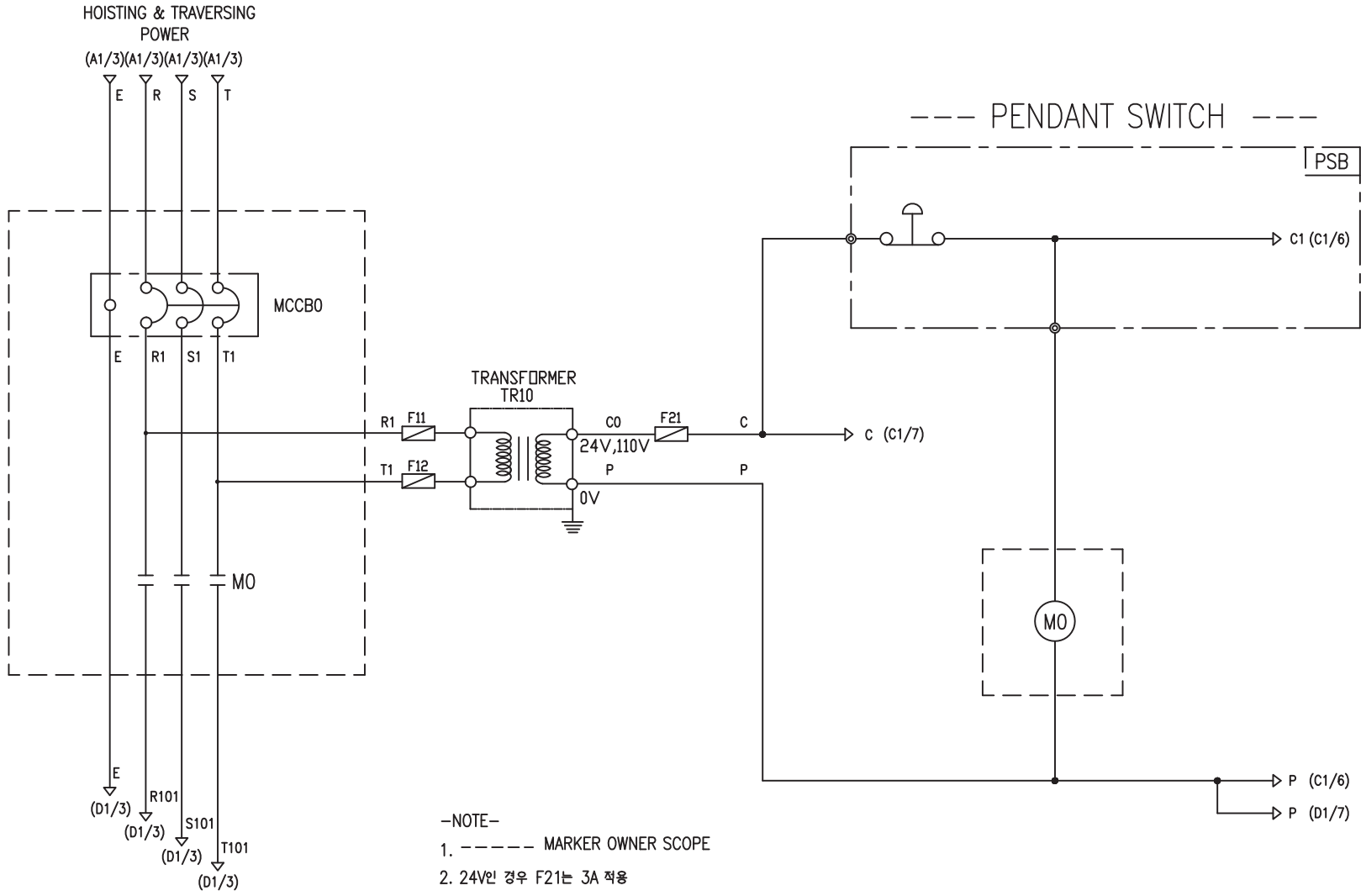

-NOTE-

1. ----- MARKER OWNER SCOPE
2. 24V인 경우 F21는 3A 적용

SPECIFICATION	NO FUSE BREAKER	MAGNET CONTACT	TRANSFORMER	FUZE
SYMBOLS	MCCB0	MO	TR10	F11, F12, F21
DESCRIPTION	220V	20A	30VA	1A
	380V	15A		
	440V	15A		
	460V	15A		
	480V	15A		
MAKER	LS	LS	DONGA	LK

TITLE MAIN POWER & CONTROL CIRCUIT DIAGRAM						PROJECTION 	
WORK NO 602		WORK NAME LTDM				SCALE 1/1	
220V, 380V, 440V, 460V, 480V						Q' TY 1	
DRAWN LEE.G.H	CHECKED	REVIEWED	APPROVED	DRAWING NO	LTDM		
2010.07.20				CODE NO			
L K HOIST CO., LTD.							

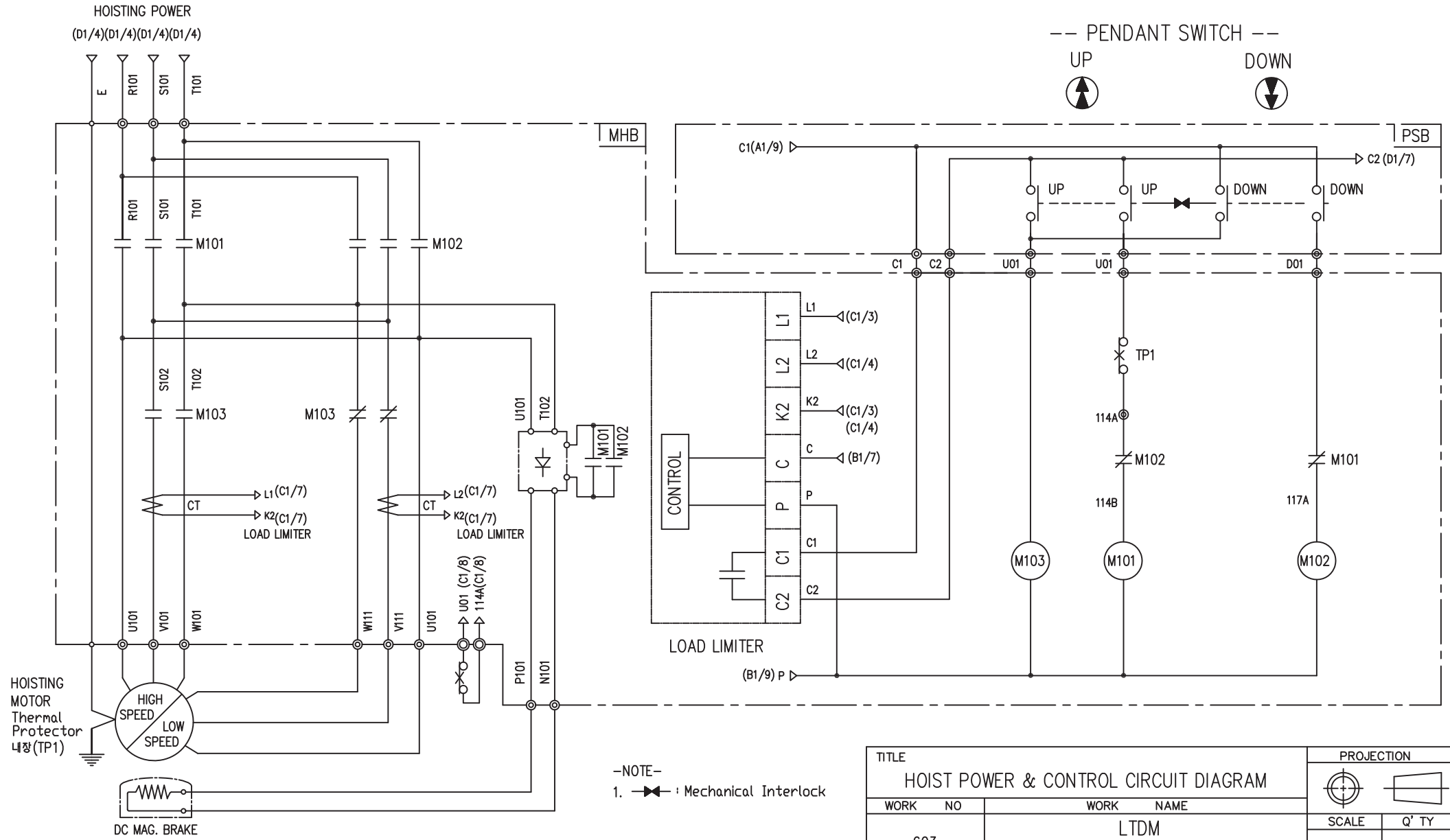

-NOTE-
1. Mechanical Interlock

TITLE HOIST POWER & CONTROL CIRCUIT DIAGRAM						PROJECTION 	
WORK NO 603		WORK NAME LTDM				SCALE 1/1	Q' TY 1
220V, 380V, 440V, 460V, 480V							
DRAWN LEE.G.H	CHECKED	REVIEWED	APPROVED	MODEL	LTDM		
2010.07.20				CODE NO			
L K HOIST CO., LTD.							

SPECIFICATION	MAGNET CONTACT	LOAD LIMITER	Thermal Protector	SILICON RECTIFIER					HOIST MOTOR	
SYMBOLS	M101, M102, M103	-	TP1	DPM30					HM	
DESCRIPTION	GMC12	DMC12	LKDL-501	17AM032	220V	380V	440V	460V	480V	2.0Kw*2P, 0.5Kw*8P
					DC99V	DC171V	DC198V	DC207V	DC216V	
MAKER	LS	DONGA	LK	Texas Instruments	LK					LK

TRAVERSING POWER CIRCUIT

TRAVERSING CONTROL CIRCUIT

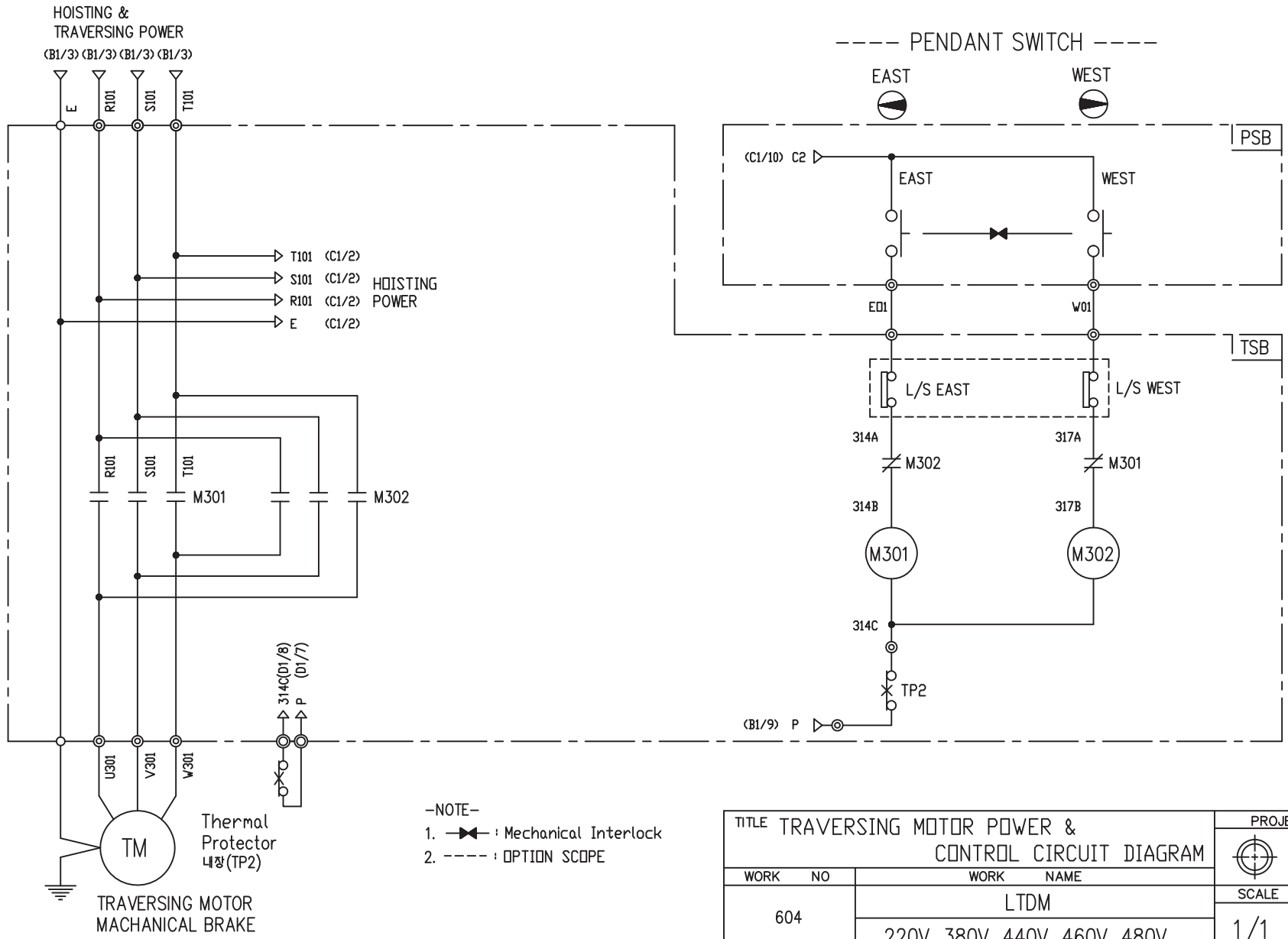

SPECIFICATION	MAGNET CONTACT	Thermal Protector	TRAVERSING MOTOR	
SYMBOLS	M301, M302	TP2	TM	
DESCRIPTION	GMC12 DMC12	17AM032	0.2KW *4P	0.3KW *2P
MAKER	LS DONGA	Texas Instruments	LK	

TITLE TRAVERSING MOTOR POWER & CONTROL CIRCUIT DIAGRAM					PROJECTION	
WORK NO. 604					WORK NAME LTDM	
220V, 380V, 440V, 460V, 480V					SCALE 1/1	Q' TY 1
DRAWN LEE.G.H	CHECKED	REVIEWED	APPROVED	MODEL LTDM		
2010.07.20				CODE NO		
LK L K HOIST CO., LTD.						

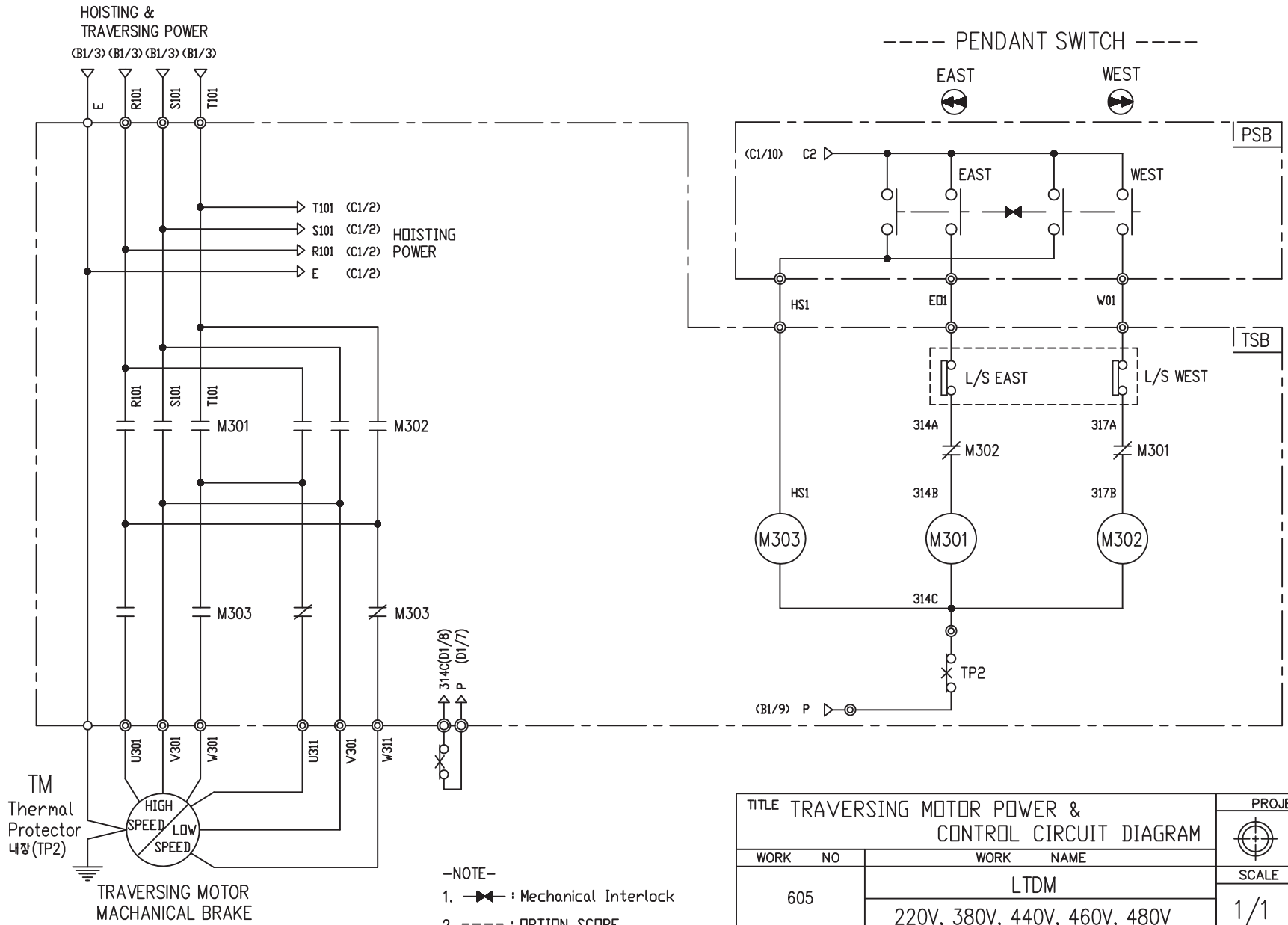

-NOTE-
 1. —|— : Mechanical Interlock
 2. - - - - : OPTION SCOPE

SPECIFICATION	MAGNET CONTACT	Thermal Protector	TRAVERSING MOTOR
SYMBOLS	M301, M302, M303	TP2	TM
DESCRIPTION	GMC12 DMC12	17AM032	0.3Kw * 2P/0.15Kw * 8P
MAKER	LS DONGA	Texas Instruments	LK

TITLE TRAVERSING MOTOR POWER & CONTROL CIRCUIT DIAGRAM					PROJECTION	
WORK NO. 605					WORK NAME LTDM	
220V, 380V, 440V, 460V, 480V					SCALE 1/1	Q' TY 1
DRAWN LEE.G.H	CHECKED	REVIEWED	APPROVED	MODEL LTDM		
2010.07.20				CODE NO		
LK L K HOIST CO., LTD.						

SCHEDULE OF TECHNICAL DATA

1. SERVICE	HOISTING
2. MANUFACTURE	LK HOIST CO. LTD
3. MOTOR MODEL NO	2.0/0.5 - 2/8 - 46
4. RATED POWER	2.0/0.5 KW × 2/8 P
5. RATED VOLTAGE AND FREQUENCY	460 V 60HZ
6. MOTOR TYPE	SQUIRREL CAGE ROTOR TYPE
7. RATING	30 MIN
8. LOCATION	IN-DOOR , OUTDOOR
9. INSULATION CLASS	B
10. DESIGN TEMPERATURE RISE (BY RESISTANCE)	80℃
11. FULL LOAD SPEED	3450 / 850 RPM
12. FULL LOAD CURRENT	4.9/2.3 A
13. STARTING CURRENT AT RATED VOLTAGE	24.5/11.5 A
14. MINIMUM STARTING VOLTAGE	414 V
15. EFFICIENCY AT 100% RATED LOAD	71 / 52 %
16. POWER FACTOR AT 100% RATED LOAD	73 / 52 %
17. STARTING TORQUE	244 / 238 %
18. TYPE OF ENCLOSURE	전폐형
19. TYPE OF BEARING	PL : 6008DD OPL : 6207ZZ
20. MOUNTING	VERTICAL
21. MAXIMUM AMBIENT TEMPURE	40℃
22. BEARING LUBRICATION	GREASE
23. STARTING METHOD	FULL VOLTAGE

SCHEDULE OF TECHNICAL DATA

1. SERVICE	TRAVERSING
2. MANUFACTURE	LK HOIST CO. LTD
3. MOTOR MODEL NO	0.3 - 2 - 46
4. RATED POWER	0.3 KW × 2 P
5. RATED VOLTAGE AND FREQUENCY	460 V 60HZ
6. MOTOR TYPE	SQUIRREL CAGE ROTOR TYPE
7. RATING	15 MIN
8. LOCATION	IN-DOOR , OUTDOOR
9. INSULATION CLASS	B
10. DESIGN TEMPERATURE RISE (BY RESISTANCE)	100℃
11. FULL LOAD SPEED	3440 RPM
12. FULL LOAD CURRENT	1.2 A
13. STARTING CURRENT AT RATED VOLTAGE	6.0 A
14. MINIMUM STARTING VOLTAGE	414 V
15. EFFICIENCY AT 100% RATED LOAD	57.3 %
16. POWER FACTOR AT 100% RATED LOAD	56.2 %
17. STARTING TORQUE	230 %
18. TYPE OF ENCLOSURE	전폐형
19. TYPE OF BEARING	PL : 6008DD OPL : 6207ZZ
20. MOUNTING	VERTICAL
21. MAXIMUM AMBIENT TEMPURE	40℃
22. BEARING LUBRICATION	GREASE
23. STARTING METHOD	FULL VOLTAGE

SCHEDULE OF TECHNICAL DATA

1. SERVICE	TRAVERSING
2. MANUFACTURE	LK HOIST CO. LTD
3. MOTOR MODEL NO	0.2 - 4 - 46
4. RATED POWER	0.2 KW × 4 P
5. RATED VOLTAGE AND FREQUENCY	460 V 60HZ
6. MOTOR TYPE	SQUIRREL CAGE ROTOR TYPE
7. RATING	15 MIN
8. LOCATION	IN-DOOR , OUTDOOR
9. INSULATION CLASS	B
10. DESIGN TEMPERATURE RISE (BY RESISTANCE)	100℃
11. FULL LOAD SPEED	1690 RPM
12. FULL LOAD CURRENT	0.96 A
13. STARTING CURRENT AT RATED VOLTAGE	4.8 A
14. MINIMUM STARTING VOLTAGE	414 V
15. EFFICIENCY AT 100% RATED LOAD	52.3 %
16. POWER FACTOR AT 100% RATED LOAD	50.0 %
17. STARTING TORQUE	230 %
18. TYPE OF ENCLOSURE	전폐형
19. TYPE OF BEARING	PL : 6008DD OPL : 6207ZZ
20. MOUNTING	VERTICAL
21. MAXIMUM AMBIENT TEMPURE	40℃
22. BEARING LUBRICATION	GREASE
23. STARTING METHOD	FULL VOLTAGE

SCHEDULE OF TECHNICAL DATA

1. SERVICE	TRAVERSING
2. MANUFACTURE	LK HOIST CO. LTD
3. MOTOR MODEL NO	0.3/0.15 - 2/8 - 46
4. RATED POWER	0.3/0.15 KW × 2/8 P
5. RATED VOLTAGE AND FREQUENCY	460 V 60HZ
6. MOTOR TYPE	SQUIRREL CAGE ROTOR TYPE
7. RATING	15 MIN
8. LOCATION	IN-DOOR , OUTDOOR
9. INSULATION CLASS	B
10. DESIGN TEMPERATURE RISE (BY RESISTANCE)	100℃
11. FULL LOAD SPEED	3440 / 840 RPM
12. FULL LOAD CURRENT	1.2 / 1.1 A
13. STARTING CURRENT AT RATED VOLTAGE	6.2 / 5.5 A
14. MINIMUM STARTING VOLTAGE	414 V
15. EFFICIENCY AT 100% RATED LOAD	56.5 / 41.8 %
16. POWER FACTOR AT 100% RATED LOAD	55.5 / 40.9 %
17. STARTING TORQUE	230 / 231 %
18. TYPE OF ENCLOSURE	전폐형
19. TYPE OF BEARING	PL : 6008DD OPL : 6207ZZ
20. MOUNTING	VERTICAL
21. MAXIMUM AMBIENT TEMPURE	40℃
22. BEARING LUBRICATION	GREASE
23. STARTING METHOD	FULL VOLTAGE