

TRAVELLING POWER
SUPPLY SYSTEM
TB1(Trolley Bar
or Festoon Type)



(B1/3) (B1/3) (B1/3) (B1/3)
(B2/3) (B2/3) (B2/3) (B2/3)
HOISTING & TRAVERSING
POWER

MAIN POWER SOURCE
AC 3Ø60Hz 220V, 380V, 440V, 460V, 480V

-NOTE-

- 1. - - - - MARKED OWNER SCOPE
- 2. ——— MARKED CRANE MAKER SCOPE

TITLE MAIN POWER CIRCUIT DIAGRAM1				PROJECTION 	
WORK NO 601	WORK NAME DBD			SCALE 1/1	Q' TY 1
220V, 380V, 440V, 460V, 480V					
DRAWN LEE.G.H 2010.08.06	CHECKED	REVIEWED	APPROVED	MODEL	
				CODE NO	
L K HOIST CO., LTD.					

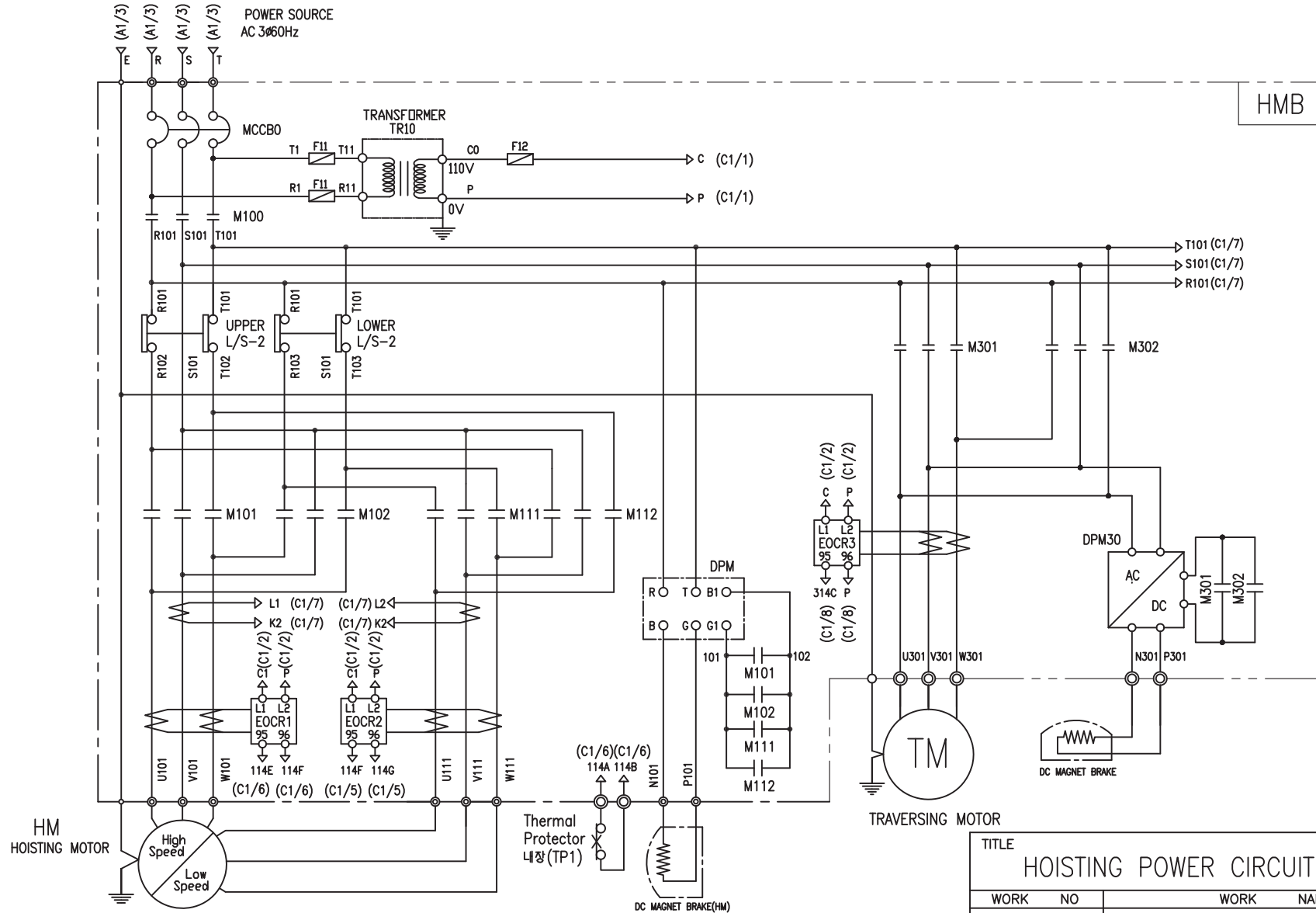

HMB

HM
HOISTING MOTOR

TRAVERSING MOTOR

TITLE HOISTING POWER CIRCUIT DIAGRAM				PROJECTION 	
WORK NO 602		WORK NAME DBD			
		220V, 440V, 460V, 480V			
SCALE	Q' TY				
DRAWN LEE.G.H	CHECKED	REVIEWED	APPROVED	MODEL	CODE NO
2010.08.06					CODE_NO
L K HOIST CO., LTD.					

SPECIFICATION	NO FUSE BREAKER	MAGNET CONTACTOR	TRANSFORMER	SILICON RECTIFIER	과전류계전기	FUSE	HOISTING MOTOR	TRAVERSING MOTOR
	MCCB0	M100 M101, M102 M111, M112	TR10	DPM, DPM30	EOCR1 EOCR2	F11 F12	HM	TM
SYMBOLS		M301, M302			EOCR3			
DESCRIPTION	220V 40A 440V 30A 460V 30A 480V 30A	DMC22 DMC32 DMC12	60 VA	AC220V AC440V AC460V AC480V DC99V DC198V DC207V DC216V	SS-30 SS-06	1A 2A	4.4Kw x 2P / 2.2Kw x 6P	0.75Kw * 4P 0.5Kw * 6P
MAKER	LS	DONGA	YOUNG DONG	LK	SAMWHA	-	LK	LK

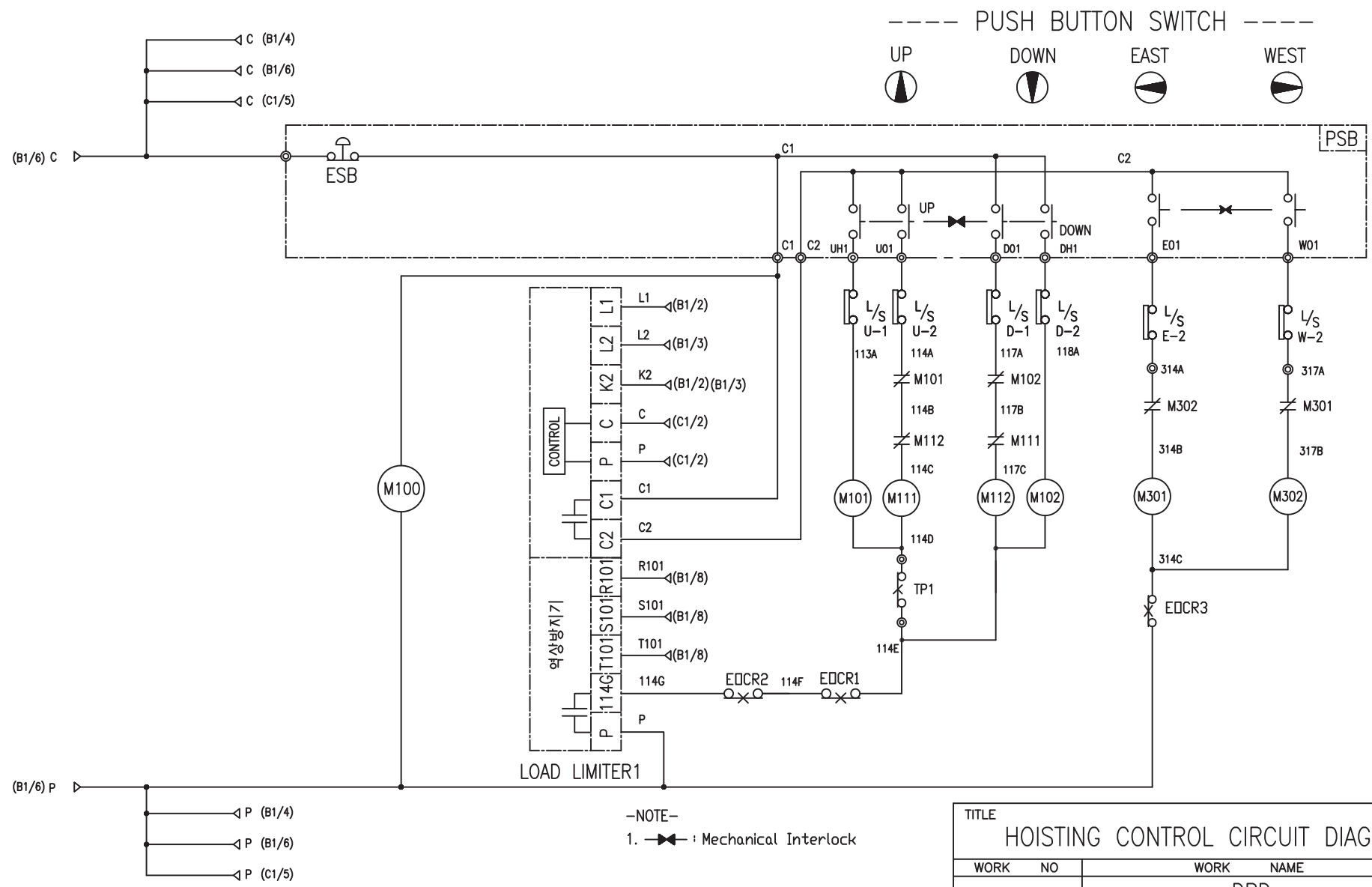

-NOTE-
1. —X— : Mechanical Interlock

SPECIFICATION	LOAD LIMITER
SYMBOLS	LKDL601
DESCRIPTION	1A - 50A
MAKER	LK

TITLE HOISTING CONTROL CIRCUIT DIAGRAM				PROJECTION 	
WORK NO. 604	WORK NAME DBD			SCALE	Q' TY
220V, 380V, 440V, 460V, 480V					
DRAWN LEE.G.H	CHECKED	REVIEWED	APPROVED	MODEL	
2010.08.06				CODE NO	CODE_NO
L K HOIST CO., LTD.					

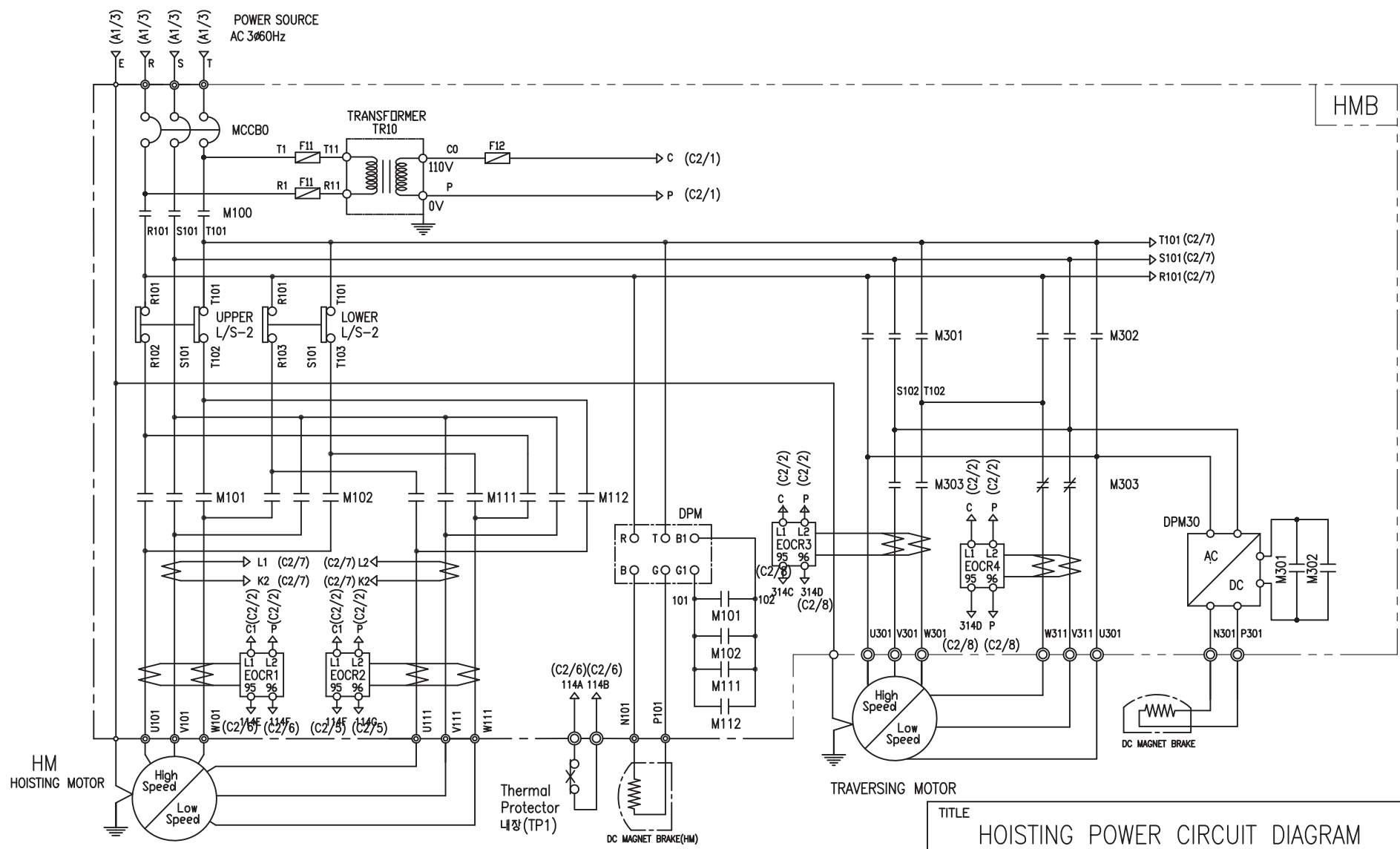

SPECIFICATION	NO FUSE BREAKER	MAGNET CONTACTOR			TRANSFORMER	SILICON RECTIFIER					과전류계전기	FUSE	HOISTING MOTOR	TRAVERSING MOTOR					
SYMBOLS	MCCB0	M100	M101, M102 M111, M112	M301, M302	TR10	DPM, DPM30					EOCR1 EOCR2	EOCR3 EOCR4	F11 F12	HM	TM				
DESCRIPTION	220V 40A 380V 30A 440V 30A 460V 30A 480V 30A	DMC22	DMC32	DMC12	60 VA	AC220V	AC380V	AC440V	AC460V	AC480V	DC99V	DC171V	DC198V	DC207V	DC216V	SS-30 SS-06	1A 2A	4.4Kw x 2P / 2.2Kw x 6P	0.75Kw * 4P / 0.25Kw * 12P
MAKER	LS	DONGA			YOUNG DONG	LK					SAMWHA		-	LK	LK				

TITLE HOISTING POWER CIRCUIT DIAGRAM										PROJECTION 	
WORK NO 605					WORK NAME DBD					SCALE Q' TY	
220V, 380V, 440V, 460V, 480V											
DRAWN LEE.G.H		CHECKED		REVIEWED		APPROVED		MODEL		CODE NO CODE_NO	
2010.08.06											
L K HOIST CO., LTD.											

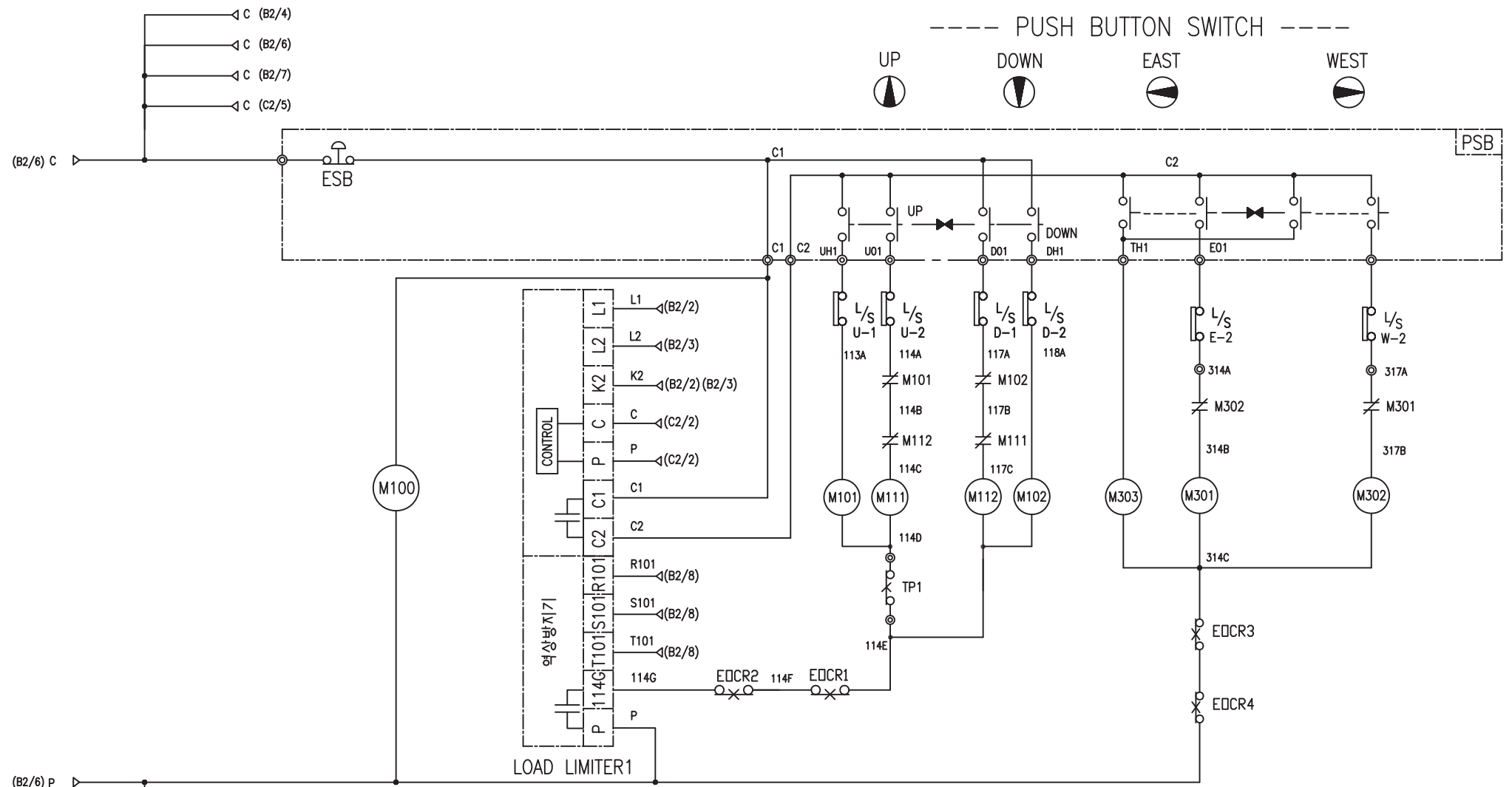

-NOTE-
1. ——— : Mechanical Interlock

SPECIFICATION	LOAD LIMITER
SYMBOLS	LKDL601
DESCRIPTION	1A - 50A
MAKER	LK

TITLE HOISTING CONTROL CIRCUIT DIAGRAM				PROJECTION 	
WORK NO 606	WORK NAME DBD			SCALE	Q' TY
220V, 380V, 440V, 460V, 480V					
DRAWN LEE.G.H	CHECKED	REVIEWED	APPROVED	MODEL	
2010.08.06				CODE NO	CODE_NO
LK L K HOIST CO., LTD.					

SCHEDULE OF TECHNICAL DATA

1. SERVICE	HOISTING
2. MANUFACTURE	LK HOIST CO. LTD
3. MOTOR MODEL NO	4.4/2.2 - 2/6 - 44
4. RATED POWER	4.4/2.2 KW × 2/6 P
5. RATED VOLTAGE AND FREQUENCY	440 V 60HZ
6. MOTOR TYPE	SQUIRREL CAGE ROTOR TYPE
7. RATING	30 MIN
8. LOCATION	OUTDOOR
9. INSULATION CLASS	B
10. DESIGN TEMPERATURE RISE (BY RESISTANCE)	80℃
11. FULL LOAD SPEED	3440/1140 RPM
12. FULL LOAD CURRENT	11.2/5.6 A
13. STARTING CURRENT AT RATED VOLTAGE	54.9/28.6 A
14. MINIMUM STARTING VOLTAGE	396 V
15. EFFICIENCY AT 100% RATED LOAD	73/73 %
16. POWER FACTOR AT 100% RATED LOAD	71/71 %
17. STARTING TORQUE	243 %
18. TYPE OF ENCLOSURE	전폐형
19. TYPE OF BEARING	PL : 6205DD OPL : 6008ZZ
20. MOUNTING	VERTICAL
21. MAXIMUM AMBIENT TEMPURE	40℃
22. BEARING LUBRICATION	GREASE
23. STARTING METHOD	FULL VOLTAGE

SCHEDULE OF TECHNICAL DATA

1. SERVICE	TRAVERSING
2. MANUFACTURE	LK HOIST CO. LTD
3. MOTOR MODEL NO	0.75 - 4 - 44
4. RATED POWER	0.75 KW × 4 P
5. RATED VOLTAGE AND FREQUENCY	440 V 60HZ
6. MOTOR TYPE	SQUIRREL CAGE ROTOR TYPE
7. RATING	15 MIN
8. LOCATION	OUTDOOR
9. INSULATION CLASS	B
10. DESIGN TEMPERATURE RISE (BY RESISTANCE)	100℃
11. FULL LOAD SPEED	1710 RPM
12. FULL LOAD CURRENT	2.4 A
13. STARTING CURRENT AT RATED VOLTAGE	13.2 A
14. MINIMUM STARTING VOLTAGE	396 V
15. EFFICIENCY AT 100% RATED LOAD	65 %
16. POWER FACTOR AT 100% RATED LOAD	63 %
17. STARTING TORQUE	249 %
18. TYPE OF ENCLOSURE	전폐형
19. TYPE OF BEARING	PL : 6008DD OPL : 6207ZZ
20. MOUNTING	VERTICAL
21. MAXIMUM AMBIENT TEMPURE	40℃
22. BEARING LUBRICATION	GREASE
23. STARTING METHOD	FULL VOLTAGE

SCHEDULE OF TECHNICAL DATA

1. SERVICE	TRAVERSING
2. MANUFACTURE	LK HOIST CO. LTD
3. MOTOR MODEL NO	0.5 - 6 - 44
4. RATED POWER	0.5 KW × 6 P
5. RATED VOLTAGE AND FREQUENCY	440 V 60HZ
6. ROTOR TYPE	SQUIRREL CAGE ROTOR TYPE
7. RATING	15 MIN
8. LOCATION	OUTDOOR
9. INSULATION CLASS	B
10. DESIGN TEMPERATURE RISE (BY RESISTANCE)	100℃
11. FULL LOAD SPEED	1140 RPM
12. FULL LOAD CURRENT	1.6 A
13. STARTING CURRENT AT RATED VOLTAGE	8.8 A
14. MINIMUM STARTING VOLTAGE	396 V
15. EFFICIENCY AT 100% RATED LOAD	65 %
16. POWER FACTOR AT 100% RATED LOAD	63 %
17. STARTING TORQUE	250 %
18. TYPE OF ENCLOSURE	전폐형
19. TYPE OF BEARING	PL : 6008DD OPL : 6207ZZ
20. MOUNTING	VERTICAL
21. MAXIMUM AMBIENT TEMPERATURE	40℃
22. BEARING LUBRICATION	GREASE
23. STARTING METHOD	FULL VOLTAGE

SCHEDULE OF TECHNICAL DATA

1. SERVICE	TRAVERSING
2. MANUFACTURE	LK HOIST CO. LTD
3. MOTOR MODEL NO	0.75/0.25 - 4/12 - 44
4. RATED POWER	0.75/0.25 KW × 4/12 P
5. RATED VOLTAGE AND FREQUENCY	440 V 60HZ
6. MOTOR TYPE	SQUIRREL CAGE ROTOR TYPE
7. RATING	15 MIN
8. LOCATION	OUTDOOR
9. INSULATION CLASS	B
10. DESIGN TEMPERATURE RISE (BY RESISTANCE)	100℃
11. FULL LOAD SPEED	1710 / 550 RPM
12. FULL LOAD CURRENT	2.4 / 1.5 A
13. STARTING CURRENT AT RATED VOLTAGE	13.2 / 8.25 A
14. MINIMUM STARTING VOLTAGE	396 V
15. EFFICIENCY AT 100% RATED LOAD	65 / 48 %
16. POWER FACTOR AT 100% RATED LOAD	63 / 46 %
17. STARTING TORQUE	250 / 243 %
18. TYPE OF ENCLOSURE	전폐형
19. TYPE OF BEARING	PL : 6008DD OPL : 6207ZZ
20. MOUNTING	VERTICAL
21. MAXIMUM AMBIENT TEMPURE	40℃
22. BEARING LUBRICATION	GREASE
23. STARTING METHOD	FULL VOLTAGE