

# L K HOIST

NO	DESCRIPTION	SIZE	MAT'L	Q'TY	WT (kg)	REMARKS

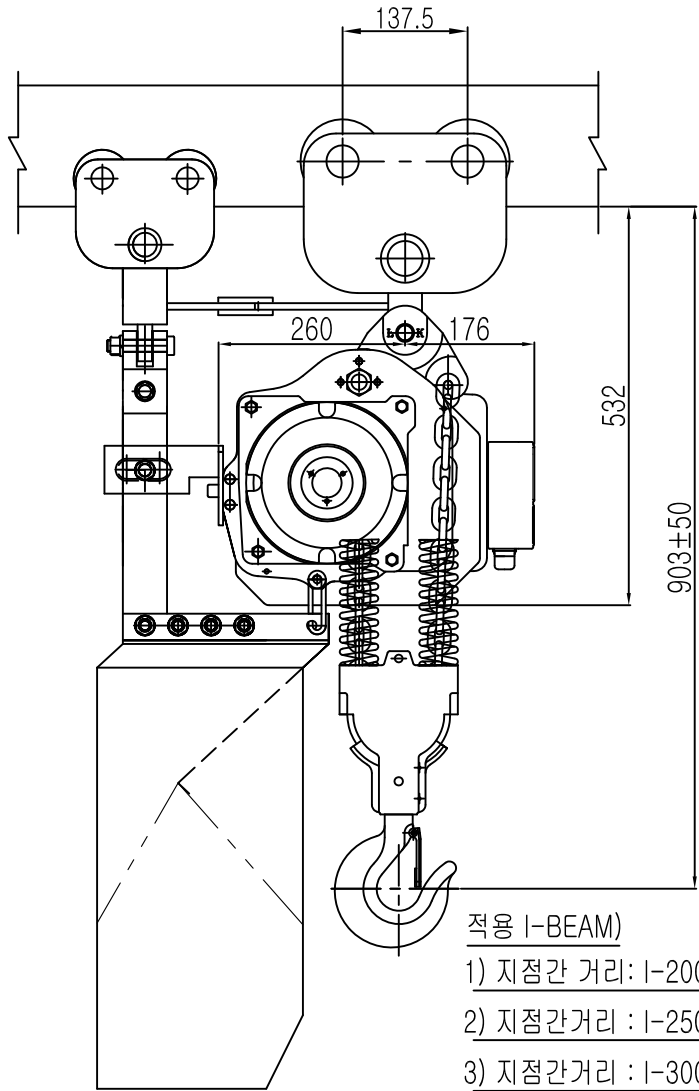

적용 I-BEAM)

- 1) 지점간 거리: I-200X100X7/10 - 2.0M
- 2) 지점간거리 : I-250X125X7.5/12.5-4.0M
- 3) 지점간거리 : I-300X150X10/18.5-6.0M
- 4) 지점간거리 : I-450X175X13/26-11M
- 5) 지점간거리 : I-600X190X13/25-14M

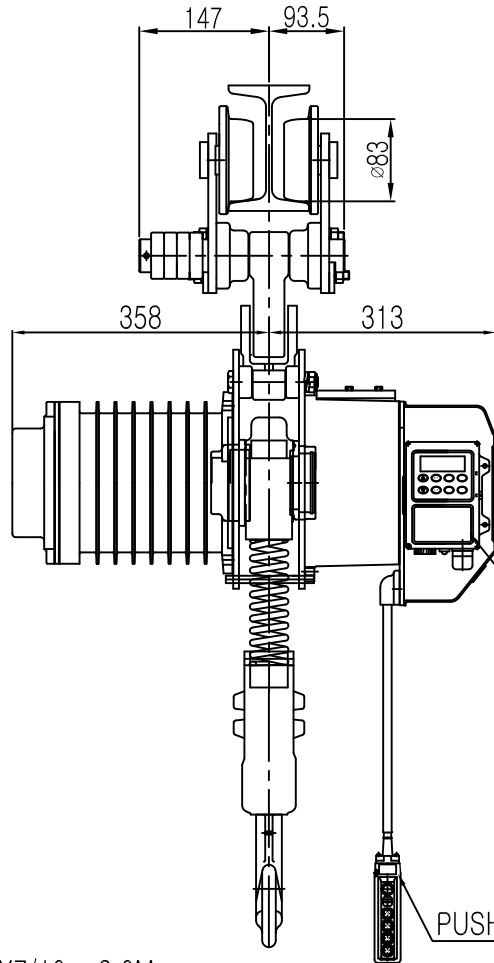

## SPECIFICATION

		LK-DAP-3W		
RATED LOAD	(TON)	3.0		
TESTING LOAD	(TON)	3.75		
LIFTING HEIGHT	(M)	50		
HOISTING	SPEED (M/MIN)	5.15		
	MOTOR (KW)	3.5kw x 4p		
TRAVERSING	SPEED (M/MIN)	-	-	-
	MOTOR (KW)	-	-	-
POWER SUPPLY	AC220.380.440.460,480Vx3 $\phi$ x 60 Hz			
OPERATING METHOD	P.B type ON . FL			
LOAD CHAIN	$\phi$ 9.5 X 28.6(2FALL)			
WEIGHT	(KG)	385KG		
I-BEAM 적용폭	100 ~ 190MM			

### NOTE)

- 1) 점검 설비를 갖출 것
- 2) 인허가 서류를 완성검사시 제출 할 것

TITLE					PROJECTION	
ELECTRIC CHAIN HOIST DAP-3W						
WORK NO	WORK NAME			SCALE	Q'TY	
	LK-DAP-3W				1	
DRAWN	CHECKED	REVIEWED	APPROVED	DRAWING NO		
김창기						
2010.08.01				CODE NO		



L K HOIST CO., LTD.

REV.NO	DATE	REVISION	DESCRIPTION	DRAWN	CHECKED	APPROVED

# L K HOIST

NO	DESCRIPTION	SIZE	MAT L	Q' TY	WT (kg)	REMARKS

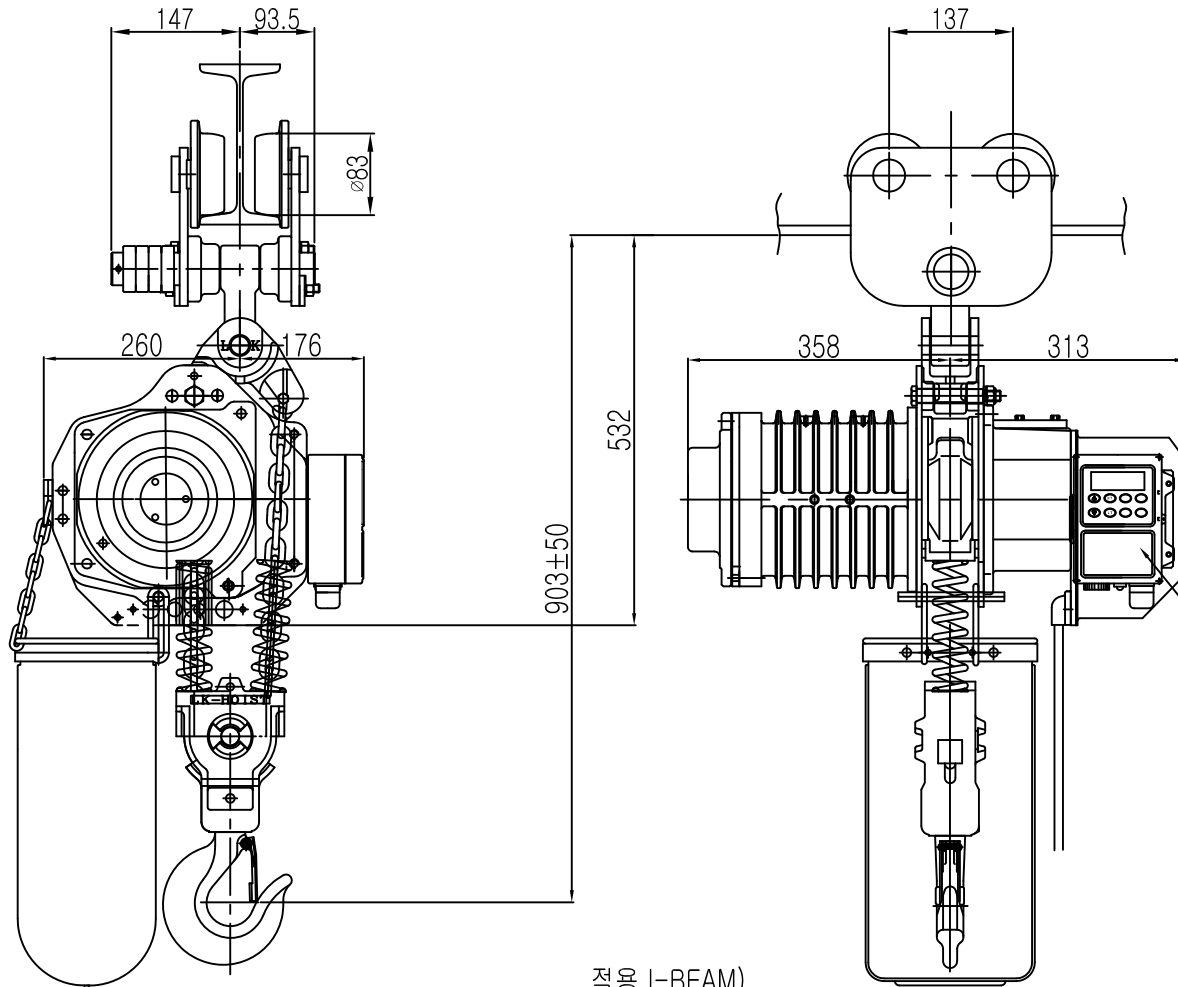

## SPECIFICATION

		LK-DAP-3W		
RATED LOAD (TON)		3.0		
TESTING LOAD (TON)		3.75		
LIFTING HEIGHT (M)		50		
HOISTING	SPEED (M/MIN)	5.15		
	MOTOR (KW)	3.5kw x 4p		
TRAVERSING	SPEED (M/MIN)	-	-	-
	MOTOR (KW)	-	-	-
POWER SUPPLY	AC220.380.440.460.480Vx3φ x 60 Hz			
OPERATING METHOD	P.B type ON . FL			
LOAD CHAIN	ø9.5 X 28.6(2FALL)			
WEIGHT (KG)	385KG			
I-BEAM 적용폭	100 ~ 190MM			

LOAD LIMITER

### NOTE)

- 1) 점검 설비를 갖출 것
- 2) 인허가 서류를 완성검사시 제출 할 것

### 적용 I-BEAM)

- 1) 지점간 거리: I-200X100X7/10 - 2.0M
- 2) 지점간거리 : I-250X125X7.5/12.5-4.0M
- 3) 지점간거리 : I-300X150X10/18.5-6.0M
- 4) 지점간거리 : I-450X175X13/26-11M
- 5) 지점간거리 : I-600X190X13/25-14M

TITLE					PROJECTION	
ELECTRIC CHAIN HOIST						
WORK NO	WORK NAME				SCALE	Q' TY
	LK-DAP-3W				N/S	1
DRAWN	CHECKED	REVIEWED	APPROVED	DRAWING NO		
김창기				CODE NO		
2010.08.01						

REV.NO	DATE	REVISION	DESCRIPTION	DRAWN	CHECKED	APPROVED