

POWER CIRCUIT
TRAVELLING POWER SUPPLY SYSTEM

ADDRESS NO.

A1

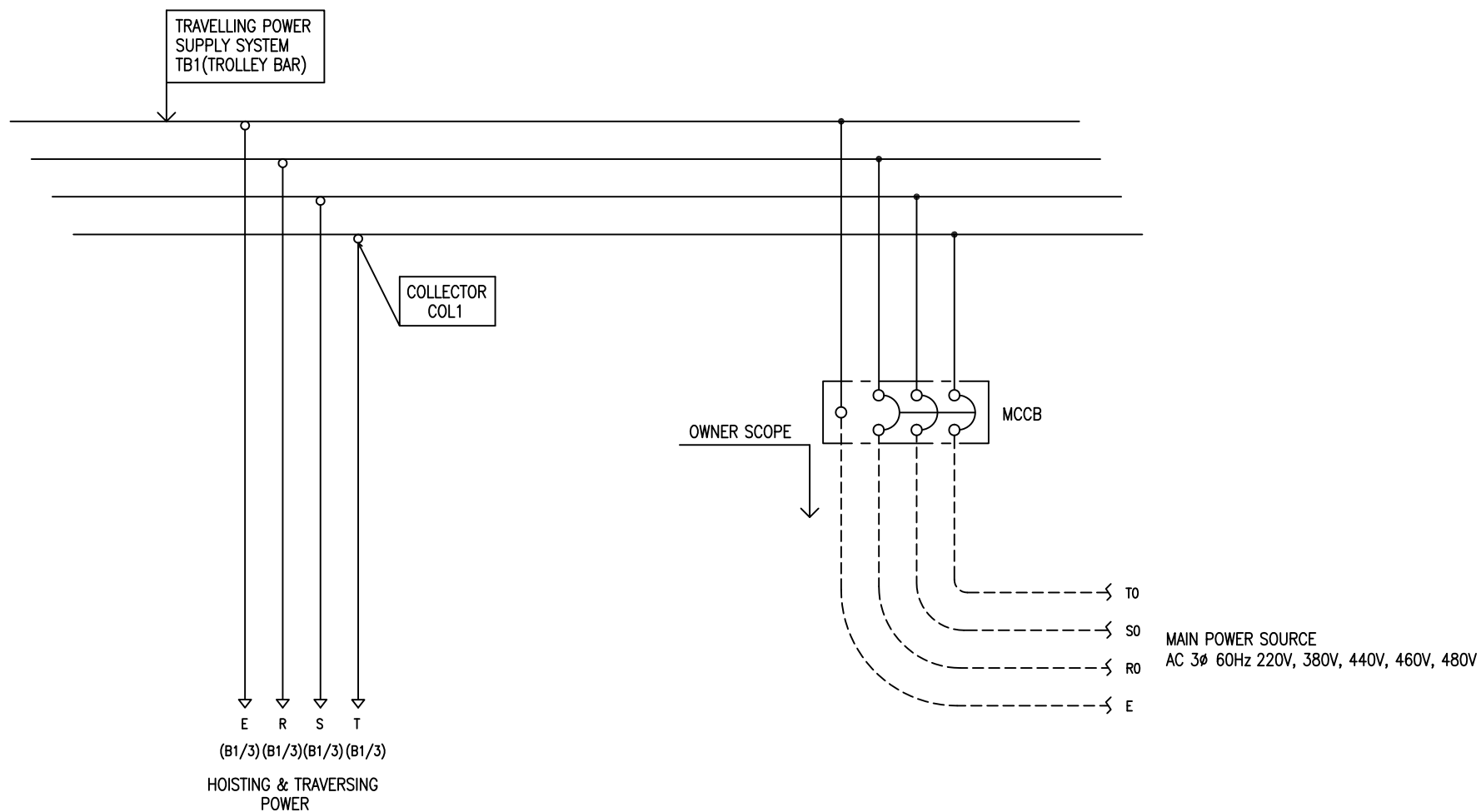

-NOTE-

1. - - - - MARKED OWNER SCOPE
2. ——— MARKED CRAIN MAKER SCOPE

TITLE				PROJECTION	
MAIN POWER CIRCUIT DIAGRAM1					
WORK NO	WORK NAME			SCALE	Q' TY
601	DAM			NA	1
220V, 380V, 440V, 460V, 480V					
DRAWN	CHECKED	REVIEWED	APPROVED	DRAWING NO	DAM
LEE G.H.				CODE NO	
2013.08.27					

POWER CIRCUIT

CONTROL CIRCUIT

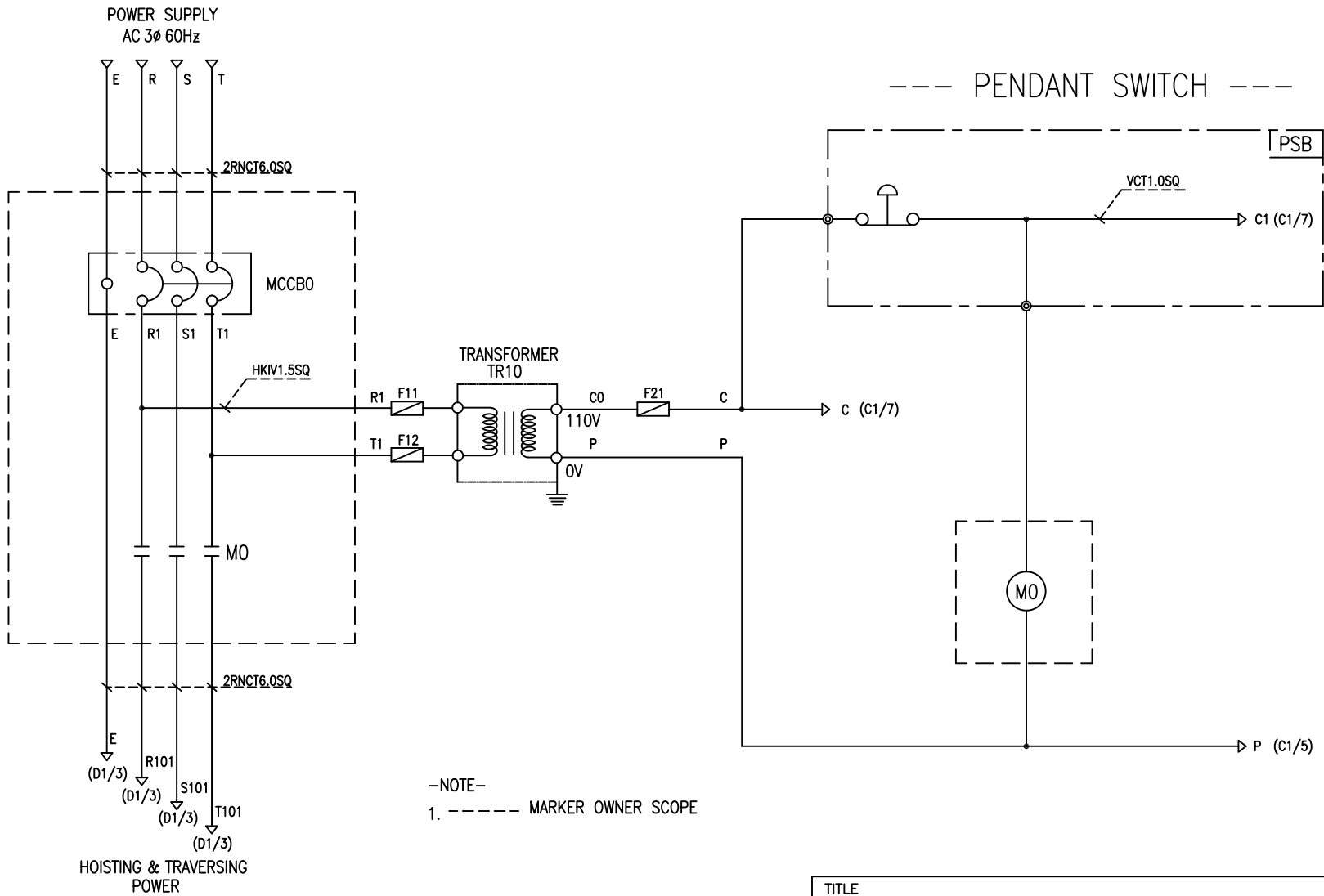

-NOTE-
1. ----- MARKER OWNER SCOPE

SPECIFICATION	NO FUSE BREAKER	MAGNET CONTACT	TRANSFORMER	FUSE		
SYMBOLS	MCCBO	MO	TR10	F11, F12, F21		
DESCRIPTION	220V	30A	GMC22	DMC-22	40VA	1A
	380V	15A				
	440V	15A				
	460V	15A				
	480V	15A				
MAKER	LS	LS	DONGA	LK	-	

TITLE						PROJECTION	
MAIN POWER & CONTROL CIRCUIT DIAGRAM							
WORK NO	WORK NAME					SCALE	Q' TY
602	DAM					NA	1
220V, 380V, 440V, 460V, 480V							
DRAWN	CHECKED	REVIEWED	APPROVED	MODEL	DAM		
LEE.G.H				CODE NO			
2013.08.27							
L K HOIST CO., LTD.							

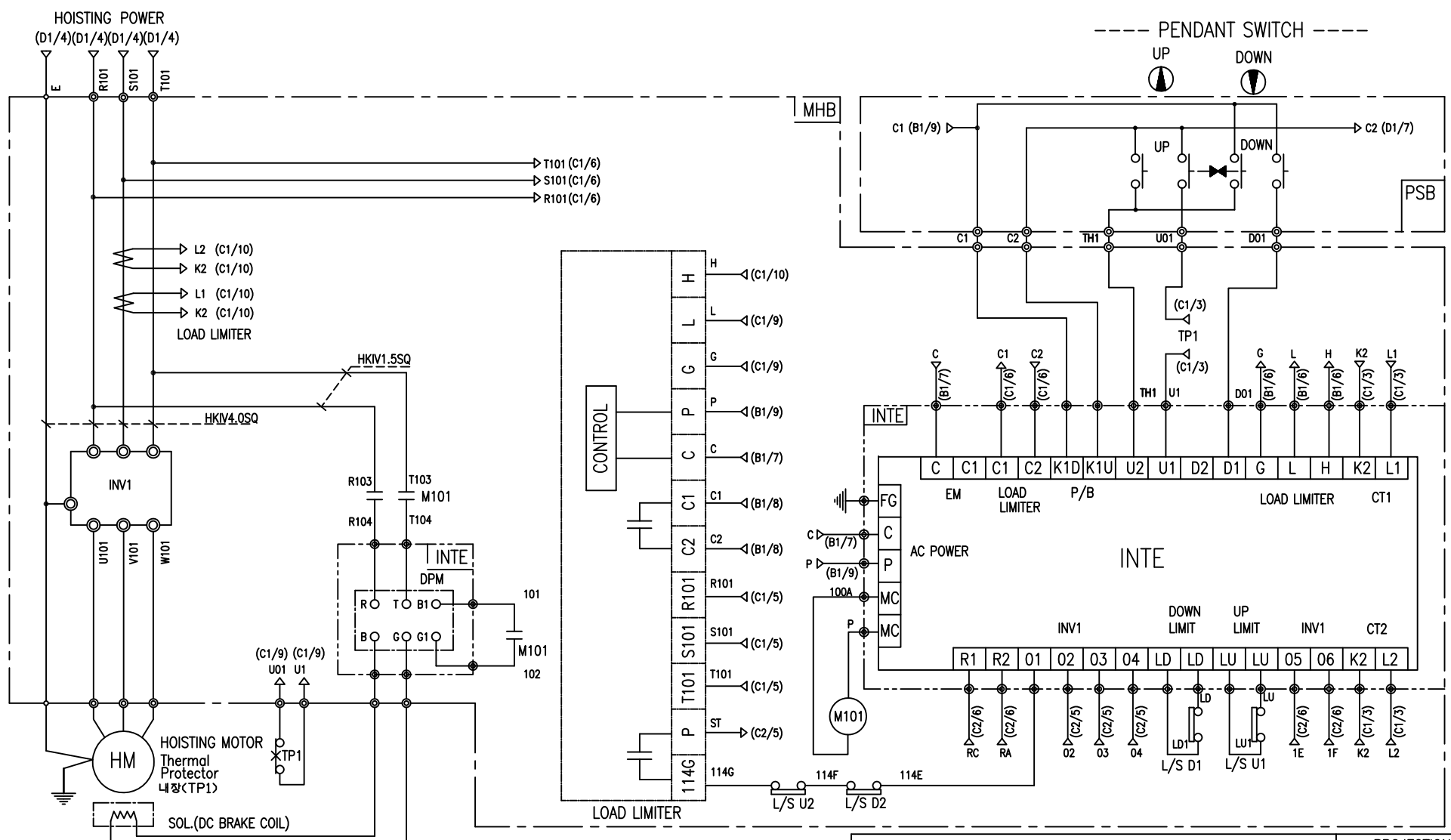

-NOTE-
1. ——— : Mechanical Interlock

SPECIFICATION	MAGNET CONTACT	LOAD LIMITER	SILICON RECTIFIER				Thermal Protector	HOIST MOTOR	
SYMBOLS	M101	-	DPM				TP1	HM	
DESCRIPTION	DMC25C	LKDL-60	AC220V	AC380V	AC440V	AC460V	AC480V	17AM032	1.8Kw * 4P
			DC99V	DC171V	DC198V	DC207V	DC216V		
MAKER	DONG-A	LK	LK				Texas Instruments	LK	

TITLE HOIST POWER & CONTROL CIRCUIT DIAGRAM						PROJECTION [Symbol]	
WORK NO 603		WORK NAME DAM				SCALE NA	Q' TY 1
220V, 380V, 440V, 460V, 480V							
DRAWN LEE.G.H	CHECKED	REVIEWED	APPROVED	MODEL DAM	CODE NO		
2013.08.27							
LK L K HOIST CO., LTD.							

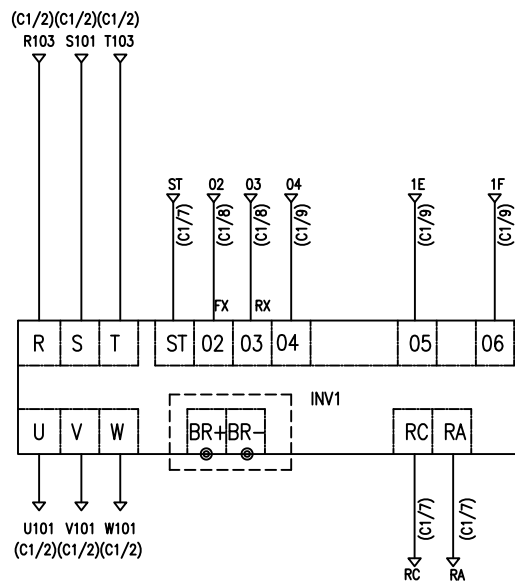

-NOTE-

1. ----- : OPTION SCOPE

SPECIFICATION	INVERTER	BRAKING RESISTOR
SYMBOLS	INV1	BR
DESCRIPTION	2.2KW	300W 250 OHM
MAKER	ROCKWELL	-

TITLE				(D1/6) PROJECTION	
INVERTER CONTROL CIRCUIT DIAGRAM					
WORK NO	WORK NAME			SCALE	Q' TY
604	HOISTING			NA	1
220V, 380V, 440V, 460V, 480V					
DRAWN	CHECKED	REVIEWED	APPROVED	MODEL	DAM
LEE.G.H				CODE NO	
2013.08.27					

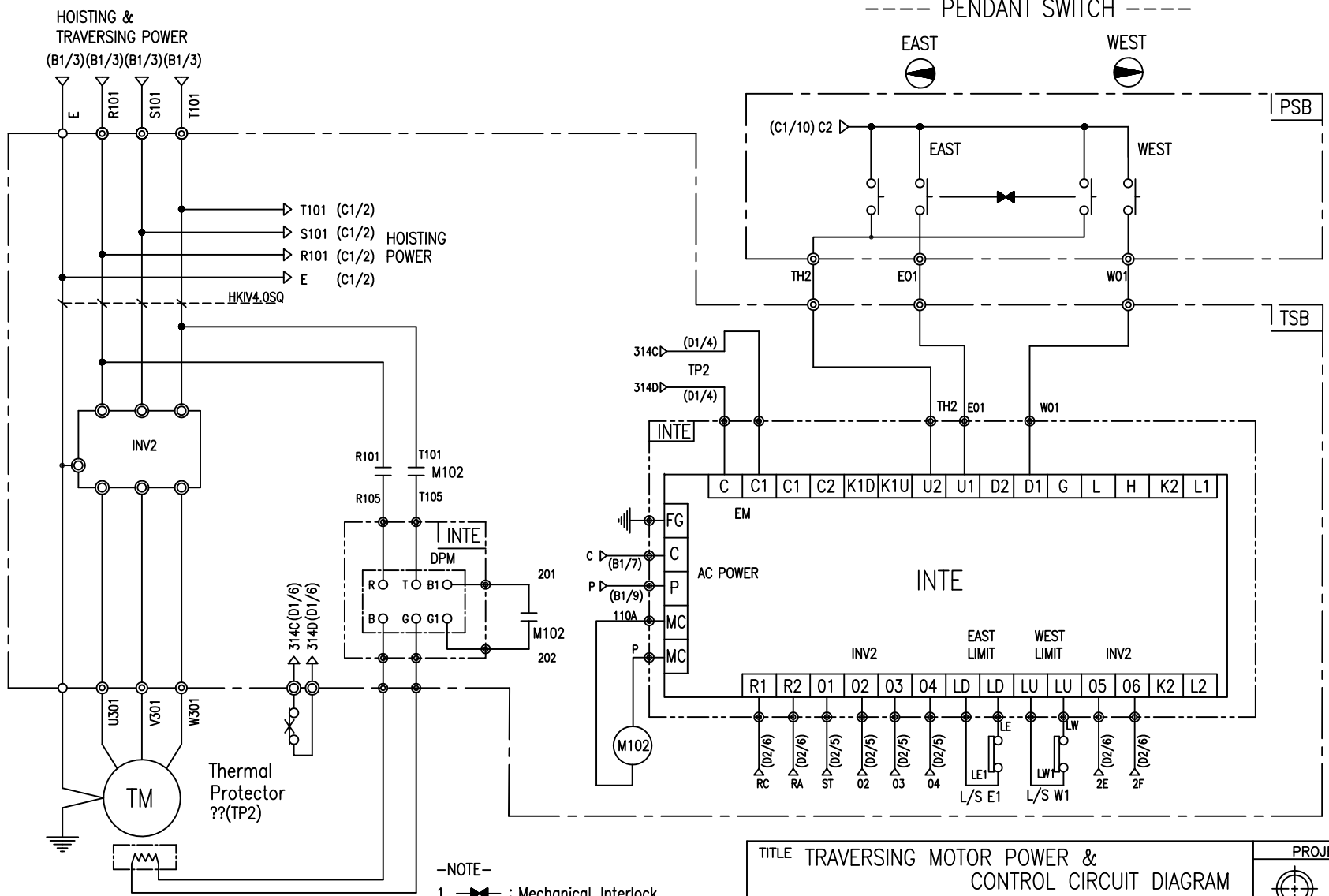

-NOTE-
 1. —|> : Mechanical Interlock
 2. - - - - : OPTION SCOPE

TITLE TRAVERSING MOTOR POWER & CONTROL CIRCUIT DIAGRAM						PROJECTION	
WORK NO 605						WORK NAME DAM	
220V, 380V, 440V, 460V, 480V						SCALE NA	Q' TY 1
DRAWN LEE.G.H	CHECKED	REVIEWED	APPROVED	MODEL	DAM		
2013.08.27				CODE NO			
LK HOIST CO., LTD.							

SPECIFICATION	MAGNET CONTACT	SILICON RECTIFIER					Thermal Protector	TRAVERSING MOTOR	
SYMBOLS	M102	DPM					TP2	TM	
DESCRIPTION	DMC12	AC220V	AC380V	AC440V	AC460V	AC480V	17AM032	0.75KW *4P	0.4KW *6P
		DC99V	DC171V	DC198V	DC207V	DC216V			
MAKER	DONG-A	LK					Texas Instruments	LK	

HOIST CONTROL CIRCUIT

ADDRESS NO.

D2

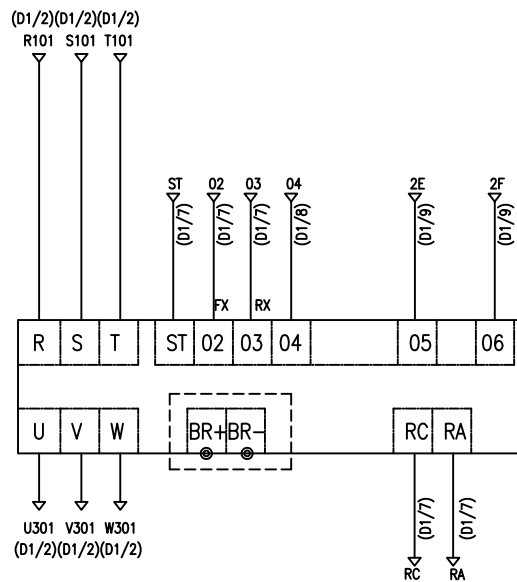

-NOTE-

1. ----- : OPTION SCOPE

SPECIFICATION	INVERTER	BRAKING RESISTOR
SYMBOLS	INV2	BR
DESCRIPTION	0.75KW	80W 750 OHM
MAKER	ROCKWELL	-

TITLE						PROJECTION	
INVERTER CONTROL CIRCUIT DIAGRAM							
WORK NO	WORK NAME					SCALE	Q' TY
606	TRAVERSING					NA	1
220V, 380V, 440V, 460V, 480V							
DRAWN	CHECKED	REVIEWED	APPROVED	MODEL	DAM		
LEE.G.H							
2013.08.27				CODE NO			

SCHEDULE OF TECHNICAL DATA

1. SERVICE	HOISTING
2. MANUFACTURE	LK HOIST CO. LTD
3. MOTOR MODEL NO	1.8 - 4 - 48
4. RATED POWER	1.8 KW × 4 P
5. RATED VOLTAGE AND FREQUENCY	480 V 60HZ
6. MOTOR TYPE	SQUIRREL CAGE ROTOR TYPE
7. RATING	30 MIN
8. LOCATION	IN-DOOR , OUTDOOR
9. INSULATION CLASS	B
10. DESIGN TEMPERATURE RISE (BY RESISTANCE)	80℃
11. FULL LOAD SPEED	1740 RPM
12. FULL LOAD CURRENT	4.3 A
13. STARTING CURRENT AT RATED VOLTAGE	21.5 A
14. MINIMUM STARTING VOLTAGE	397 V
15. EFFICIENCY AT 100% RATED LOAD	72.3 %
16. POWER FACTOR AT 100% RATED LOAD	69.6 %
17. STARTING TORQUE	244 %
18. TYPE OF ENCLOSURE	전폐형
19. TYPE OF BEARING	PL : 6008DD OPL : 6207ZZ
20. MOUNTING	VERTICAL
21. MAXIMUM AMBIENT TEMPURE	40℃
22. BEARING LUBRICATION	GREASE
23. STARTING METHOD	FULL VOLTAGE

SCHEDULE OF TECHNICAL DATA

1. SERVICE	TRAVERSING
2. MANUFACTURE	LK HOIST CO. LTD
3. MOTOR MODEL NO	0.75 - 4 - 48
4. RATED POWER	0.75 KW × 4 P
5. RATED VOLTAGE AND FREQUENCY	480 V 60HZ
6. MOTOR TYPE	SQUIRREL CAGE ROTOR TYPE
7. RATING	15 MIN
8. LOCATION	OUTDOOR
9. INSULATION CLASS	B
10. DESIGN TEMPERATURE RISE (BY RESISTANCE)	100℃
11. FULL LOAD SPEED	1670 RPM
12. FULL LOAD CURRENT	2.2 A
13. STARTING CURRENT AT RATED VOLTAGE	12.1 A
14. MINIMUM STARTING VOLTAGE	432 V
15. EFFICIENCY AT 100% RATED LOAD	65 %
16. POWER FACTOR AT 100% RATED LOAD	63 %
17. STARTING TORQUE	250 %
18. TYPE OF ENCLOSURE	전폐형
19. TYPE OF BEARING	PL : 6008DD OPL : 6207ZZ
20. MOUNTING	VERTICAL
21. MAXIMUM AMBIENT TEMPURE	40℃
22. BEARING LUBRICATION	GREASE
23. STARTING METHOD	FULL VOLTAGE

SCHEDULE OF TECHNICAL DATA

1. SERVICE	TRAVERSING
2. MANUFACTURE	LK HOIST CO. LTD
3. MOTOR MODEL NO	0.4 - 6 - 48
4. RATED POWER	0.4 KW × 6 P
5. RATED VOLTAGE AND FREQUENCY	480 V 60HZ
6. ROTOR TYPE	SQUIRREL CAGE ROTOR TYPE
7. RATING	15 MIN
8. LOCATION	OUTDOOR
9. INSULATION CLASS	B
10. DESIGN TEMPERATURE RISE (BY RESISTANCE)	100℃
11. FULL LOAD SPEED	1140 RPM
12. FULL LOAD CURRENT	1.47 A
13. STARTING CURRENT AT RATED VOLTAGE	8.1 A
14. MINIMUM STARTING VOLTAGE	432 V
15. EFFICIENCY AT 100% RATED LOAD	65 %
16. POWER FACTOR AT 100% RATED LOAD	63 %
17. STARTING TORQUE	249 %
18. TYPE OF ENCLOSURE	전폐형
19. TYPE OF BEARING	PL : 6008DD OPL : 6207ZZ
20. MOUNTING	VERTICAL
21. MAXIMUM AMBIENT TEMPERATURE	40℃
22. BEARING LUBRICATION	GREASE
23. STARTING METHOD	FULL VOLTAGE