

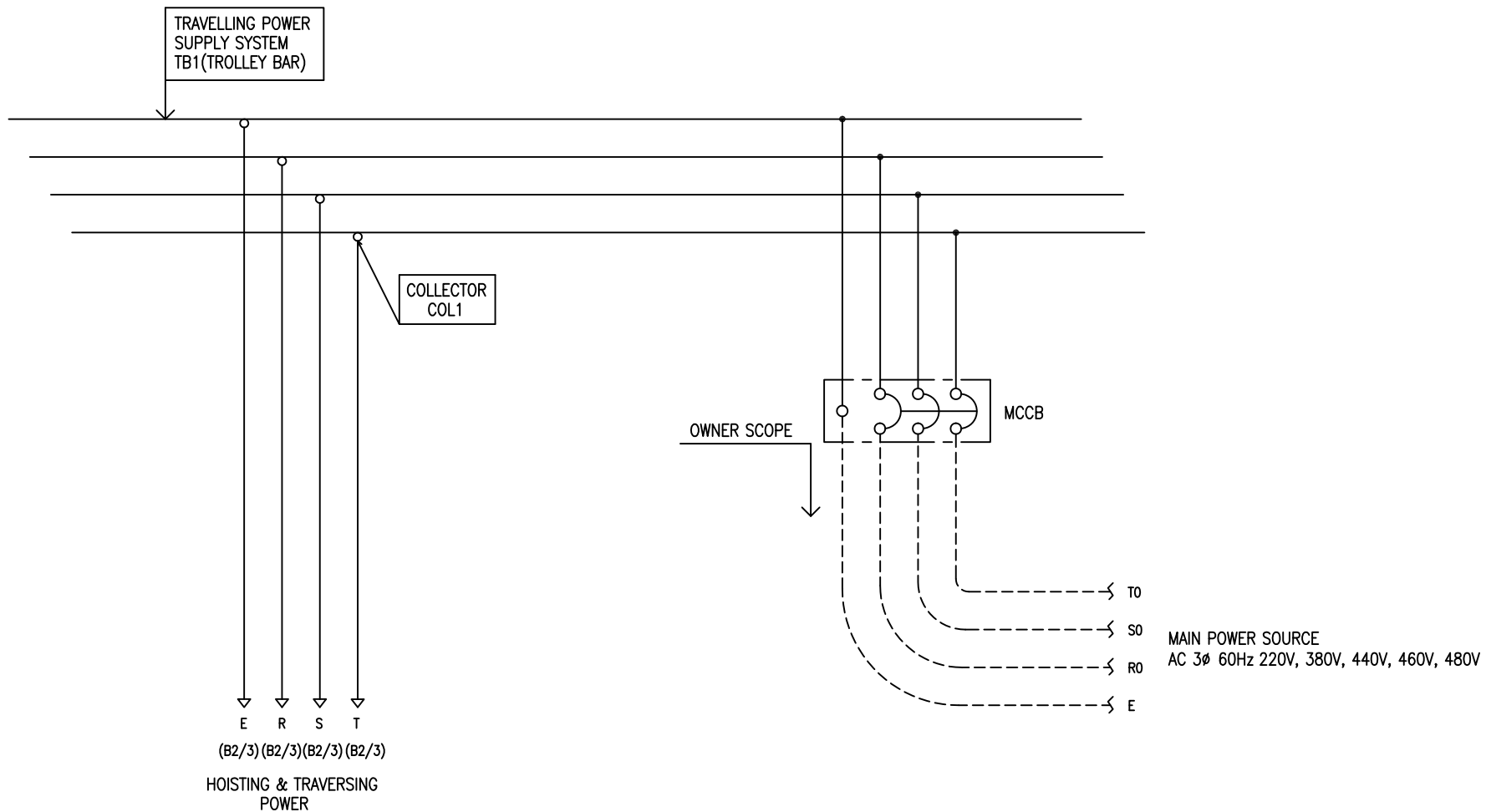

POWER CIRCUIT
TRAVELLING POWER SUPPLY SYSTEM

ADDRESS NO.
A2

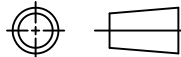

-NOTE-

- 1. - - - - MARKED OWNER SCOPE
- 2. ———— MARKED CRAIN MAKER SCOPE

TITLE MAIN POWER CIRCUIT DIAGRAM1				PROJECTION 	
WORK NO	WORK NAME			SCALE	Q' TY
601	EDAM			1/1	1
220V, 380V, 440V, 460V, 480V					
DRAWN	CHECKED	REVIEWED	APPROVED	DRAWING NO	EDAM
LEE G.H.				CODE NO	
2018.03.08					
 L K HOIST CO., LTD.					

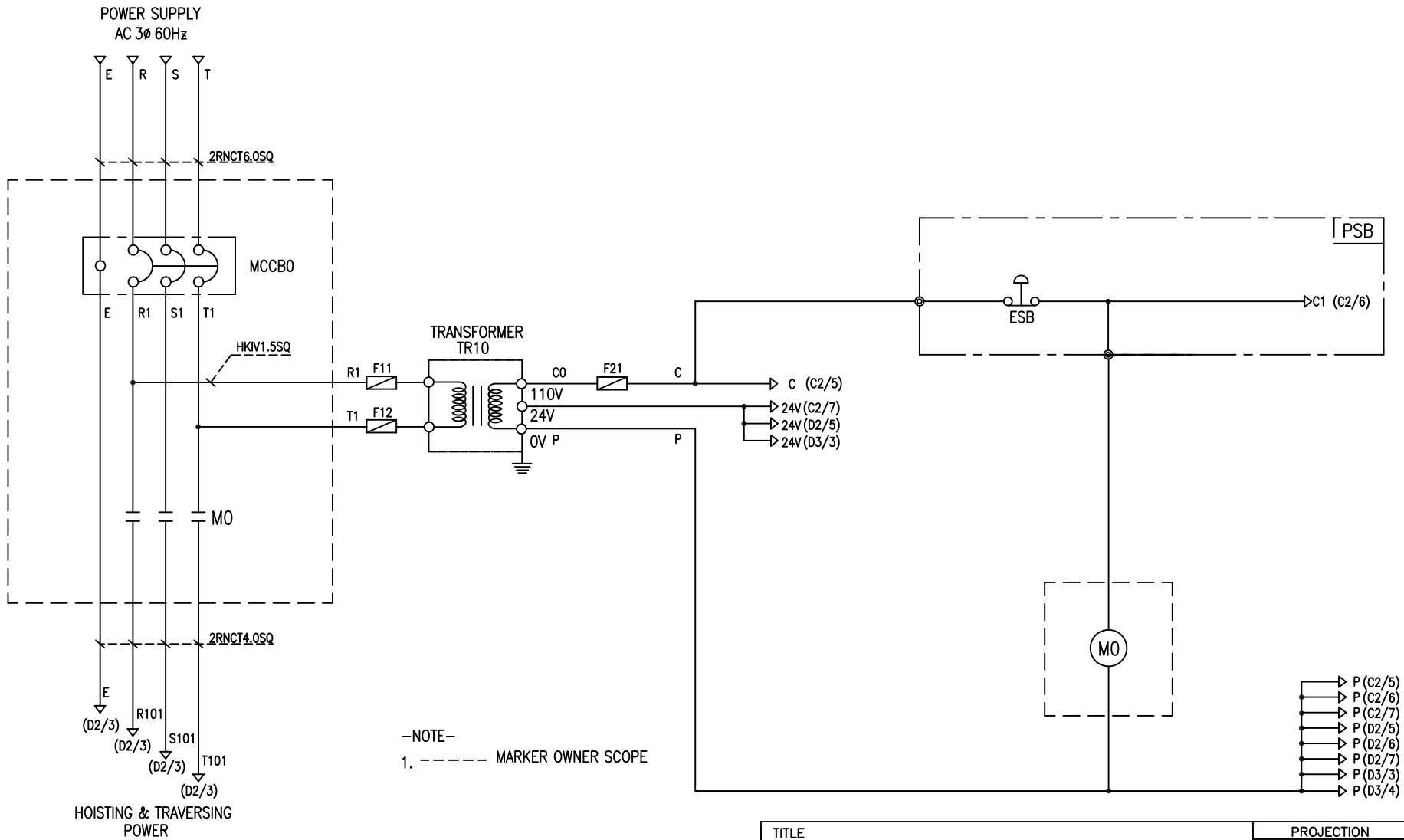

-NOTE-
1. ----- MARKER OWNER SCOPE

SPECIFICATION	NO FUSE BREAKER	MAGNET CONTACT	TRANSFORMER	FUSE		
SYMBOLS	MCCBO	MO	TR10	F11, F12, F21		
DESCRIPTION	220V	50A	GMC22	DMC-22	40VA	1A
	380V	30A				
	440V	20A				
	460V	20A				
	480V	20A				
MAKER	LS	LS	DONGA	LK	-	

TITLE MAIN POWER & CONTROL CIRCUIT DIAGRAM						PROJECTION 	
WORK NO	WORK NAME					SCALE	Q' TY
602	EDAM					1/1	1
220V, 380V, 440V, 460V, 480V							
DRAWN	CHECKED	REVIEWED	APPROVED	MODEL	EDAM		
LEE.G.H				CODE NO			
2018.03.08							
L K HOIST CO., LTD.							

HOIST POWER CIRCUIT

HOIST CONTROL CIRCUIT

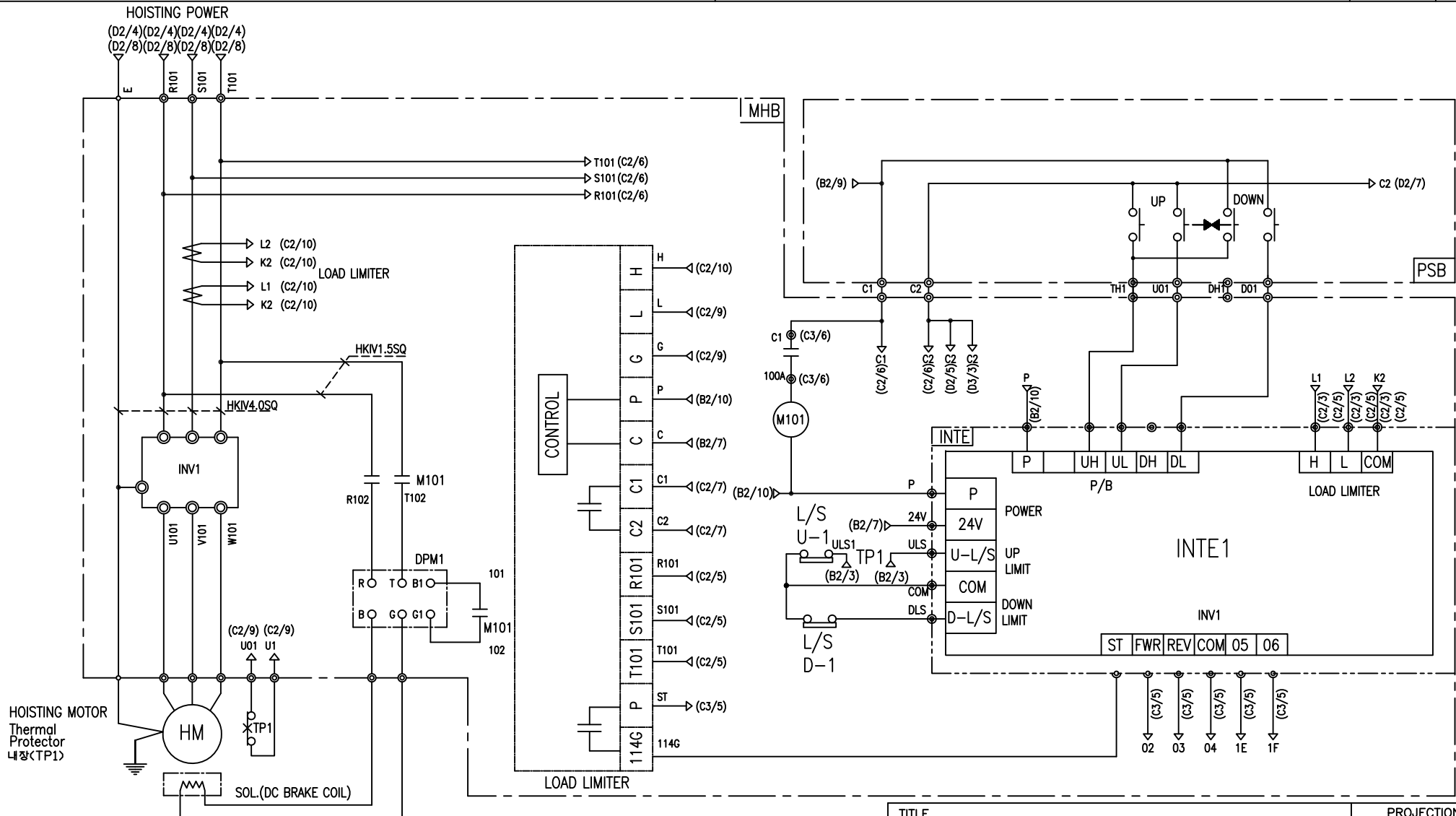

-NOTE-
1. : Mechanical Interlock

TITLE HOIST POWER & CONTROL CIRCUIT DIAGRAM						PROJECTION 	
WORK NO 603		WORK NAME EDAM				SCALE 1/1	Q' TY 1
220V, 380V, 440V, 460V, 480V							
DRAWN LEE.G.H	CHECKED	REVIEWED	APPROVED	MODEL EDAM	CODE NO		
2018.03.08							
L K HOIST CO., LTD.							

SPECIFICATION	MAGNET CONTACT	LOAD LIMITER	SILICON RECTIFIER				Thermal Protector	HOIST MOTOR	
SYMBOLS	M101	-	DPM1				TP1	HM	
DESCRIPTION	DMC25C	LKDL-80	AC220V	AC380V	AC440V	AC460V	AC480V	17AM032	3.5Kw * 4P
			DC99V	DC171V	DC198V	DC207V	DC216V		
MAKER	DONG-A	LK	LK				Texas Instruments	LK	

HOIST CONTROL CIRCUIT

ADDRESS NO.

C3

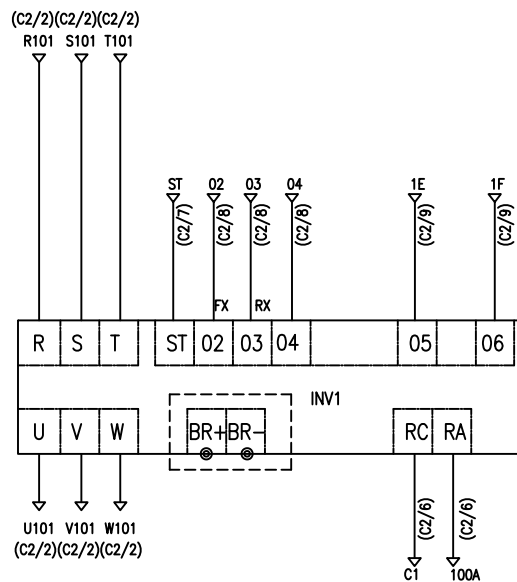

-NOTE-

1. ----- : OPTION SCOPE

SPECIFICATION	INVERTER	BRAKING RESISTOR
SYMBOLS	INV1	BR
DESCRIPTION	3.7KW	400W 150 OHM
MAKER	ROCKWELL or LS	-

TITLE				(D1/6) PROJECTION	
INVERTER CONTROL CIRCUIT DIAGRAM					
WORK NO	WORK NAME			SCALE	Q' TY
604	HOISTING			1/1	1
220V, 380V, 440V, 460V, 480V					
DRAWN	CHECKED	REVIEWED	APPROVED	MODEL	EDAM
LEE.G.H				CODE NO	
2018.03.08					

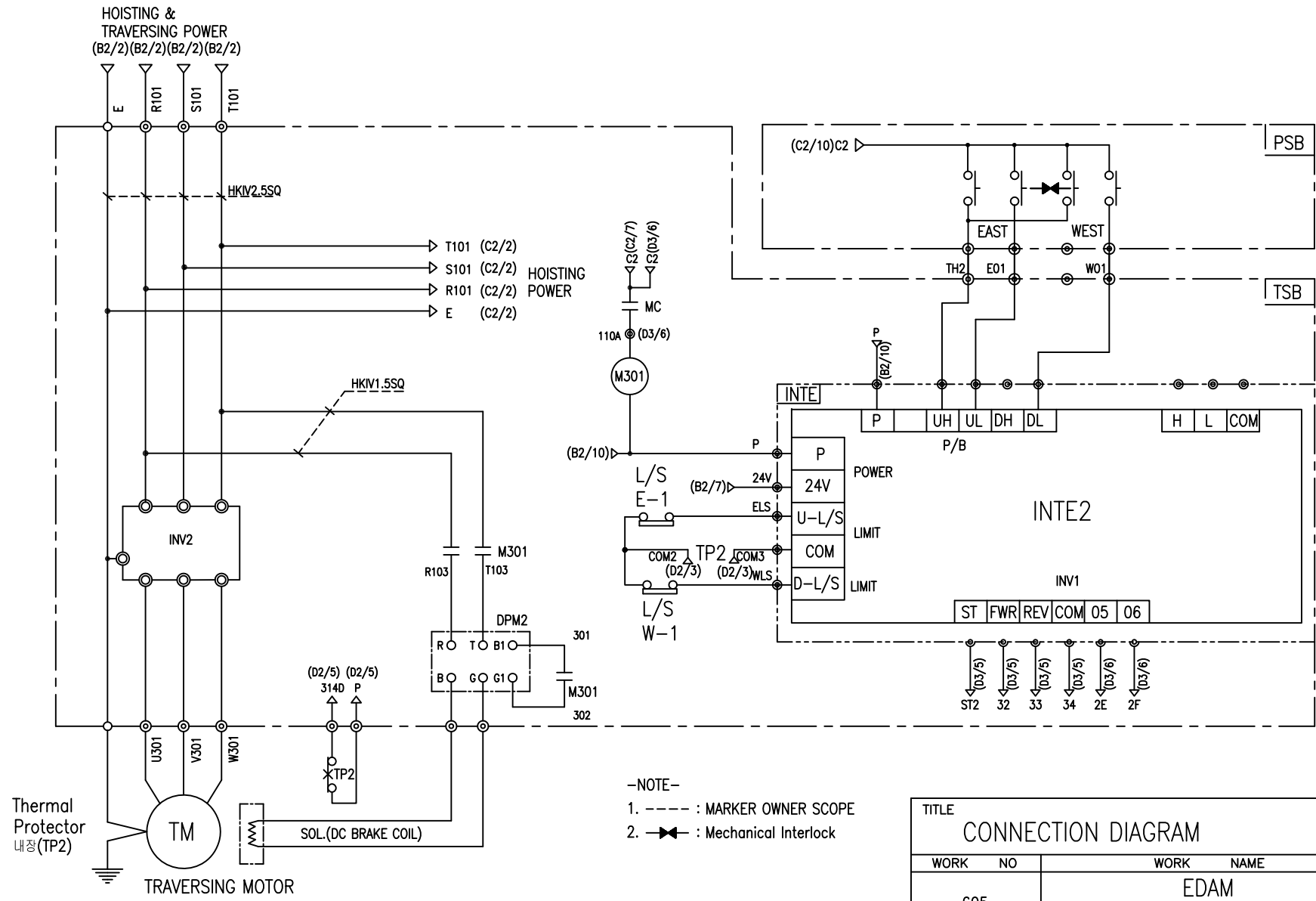

SPECIFICATION	MAGNET CONTACT	SILICON RECTIFIER					Thermal Protector	HOIST MOTOR
SYMBOLS	M301	DPM2					TP2	TM
DESCRIPTION	DMC12b	AC220V	AC380V	AC440V	AC460V	AC480V	17AM032	0.75Kw * 4P
		DC99V	DC171V	DC198V	DC207V	DC216V		0.4Kw * 6P
MAKER	DONG-A	LK					Texas Instruments	LK

TITLE CONNECTION DIAGRAM						PROJECTION	
WORK NO 605		WORK NAME EDAM				SCALE Q' TY	
220V, 380V, 440V, 460V, 480V							
DRAWN LEE.G.H	CHECKED	REVIEWED	APPROVED	MODEL	EDAM		
2018.03.08				CODE NO	CODE_NO		
L K HOIST CO., LTD.							

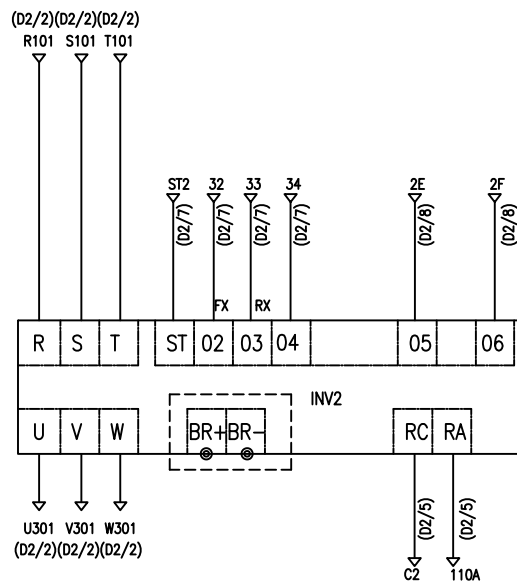

-NOTE-

1. - - - - : OPTION SCOPE

SPECIFICATION	INVERTER	BRAKING RESISTOR
SYMBOLS	INV2	BR
DESCRIPTION	0.75KW	80W 750 OHM
MAKER	ROCKWELL or LS	-

TITLE				(D1/6) PROJECTION	
INVERTER CONTROL CIRCUIT DIAGRAM					
WORK NO	WORK NAME			SCALE	Q' TY
606	TRAVERSING			1/1	1
220V, 380V, 440V, 460V, 480V					
DRAWN	CHECKED	REVIEWED	APPROVED	MODEL	EDAM
LEE.G.H					
2018.03.08				CODE NO	

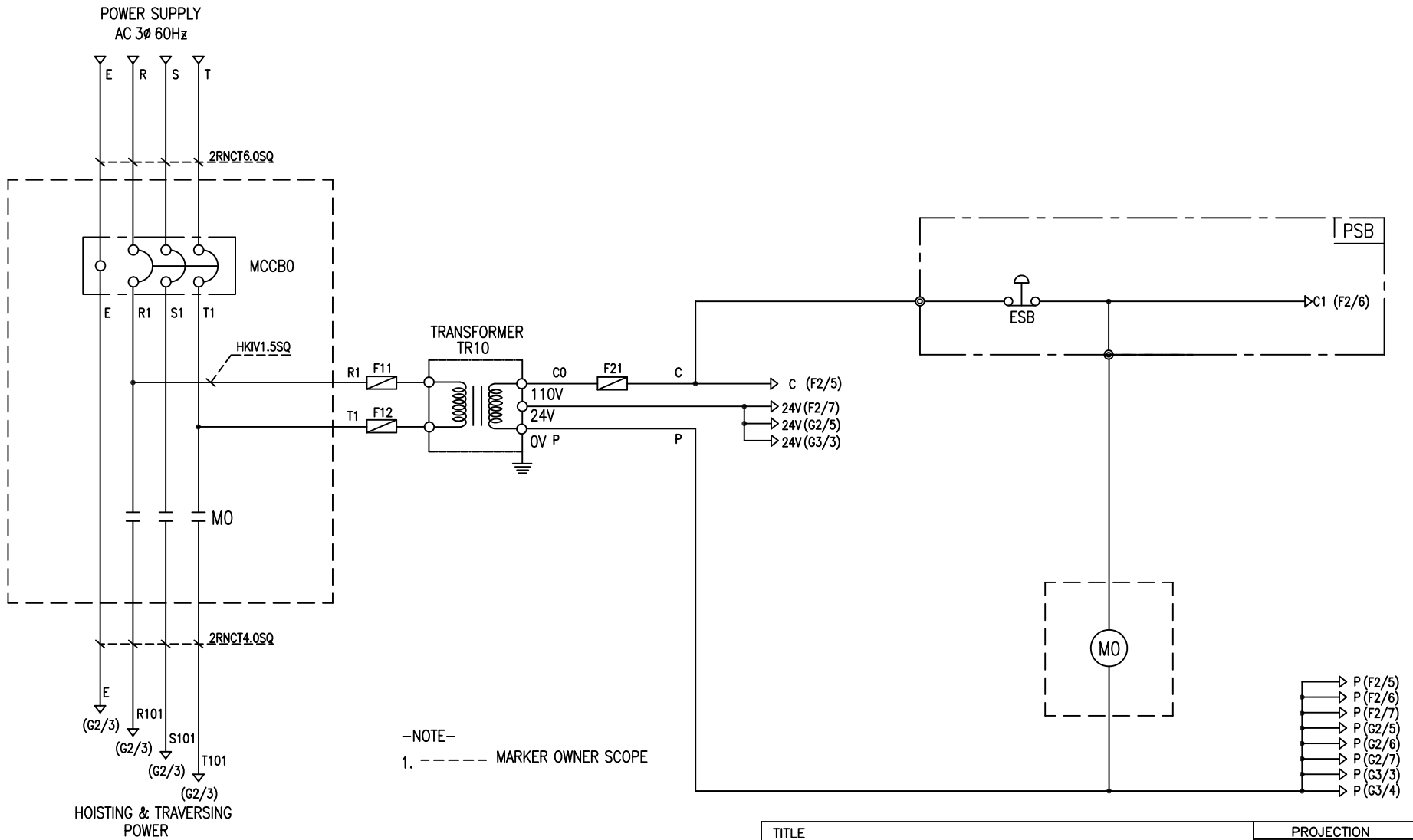

-NOTE-
1. ----- MARKER OWNER SCOPE

SPECIFICATION	NO FUSE BREAKER	MAGNET CONTACT	TRANSFORMER	FUSE		
SYMBOLS	MCCBO	MO	TR10	F11, F12, F21		
DESCRIPTION	220V	50A	GMC22	DMC-22	40VA	1A
	380V	30A				
	440V	30A				
	460V	30A				
	480V	20A				
MAKER	LS	LS	DONGA	LK	-	

TITLE						PROJECTION	
MAIN POWER & CONTROL CIRCUIT DIAGRAM							
WORK NO	WORK NAME					SCALE	Q' TY
607	EDAM					1/1	1
220V, 380V, 440V, 460V, 480V							
DRAWN	CHECKED	REVIEWED	APPROVED	MODEL	EDAM		
LEE.G.H				CODE NO			
2018.03.08							
L K HOIST CO., LTD.							

HOIST POWER CIRCUIT

HOIST CONTROL CIRCUIT

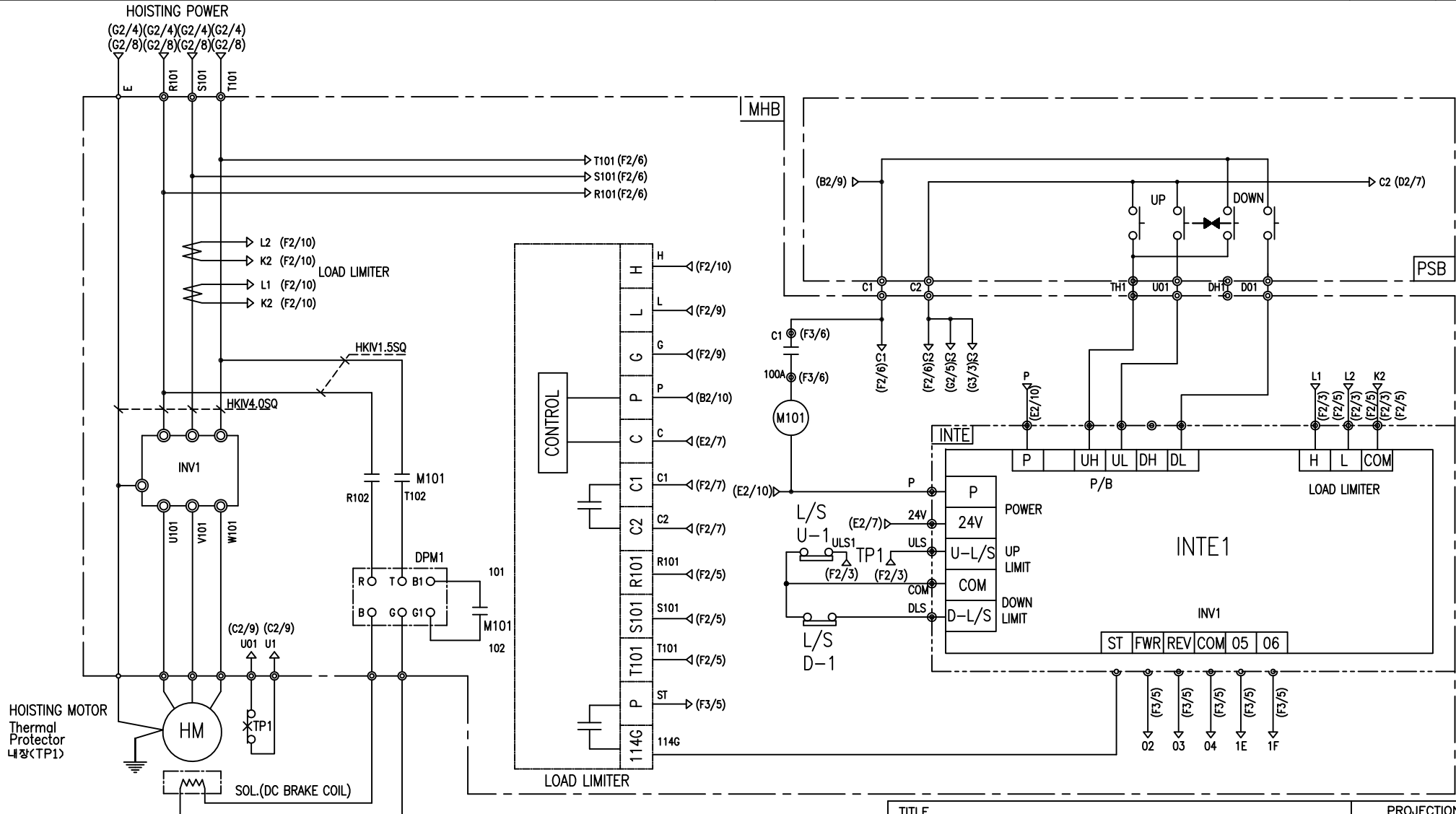

-NOTE-
1. : Mechanical Interlock

TITLE HOIST POWER & CONTROL CIRCUIT DIAGRAM						PROJECTION 	
WORK NO 608		WORK NAME EDAM				SCALE 1/1	Q' TY 1
220V, 380V, 440V, 460V, 480V							
DRAWN LEE.G.H	CHECKED	REVIEWED	APPROVED	MODEL EDAM	CODE NO		
2018.03.08							
L K HOIST CO., LTD.							

SPECIFICATION	MAGNET CONTACT	LOAD LIMITER	SILICON RECTIFIER				Thermal Protector	HOIST MOTOR
SYMBOLS	M101	-	DPM1				TP1	HM
DESCRIPTION	DMC25C	LKDL-80	AC220V DC99V	AC380V DC171V	AC440V DC198V	AC460V DC207V	AC480V DC216V	17AM032 3.5Kw * 4P
MAKER	DONG-A	LK	LK				Texas Instruments	LK

HOIST CONTROL CIRCUIT

ADDRESS NO.

F3

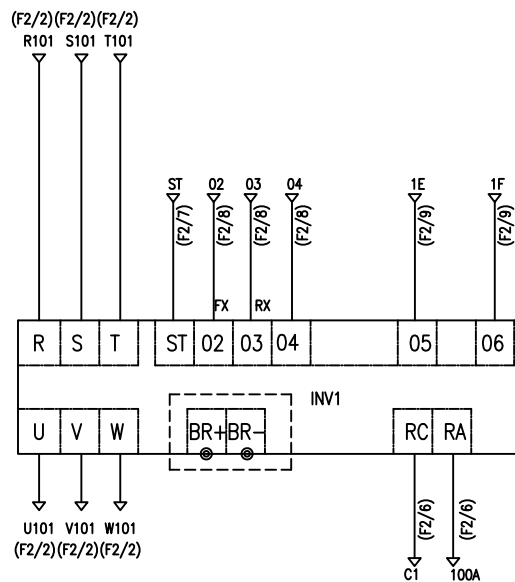

-NOTE-

1. ----- : OPTION SCOPE

SPECIFICATION	INVERTER	BRAKING RESISTOR
SYMBOLS	INV1	BR
DESCRIPTION	3.7KW	400W 150 OHM
MAKER	ROCKWELL or LS	-

TITLE				PROJECTION	
INVERTER CONTROL CIRCUIT DIAGRAM					
WORK NO	WORK NAME			SCALE	Q' TY
609	HOISTING			1/1	1
220V, 380V, 440V, 460V, 480V					
DRAWN	CHECKED	REVIEWED	APPROVED	MODEL	EDAM
LEE.G.H				CODE NO	
2018.03.08					

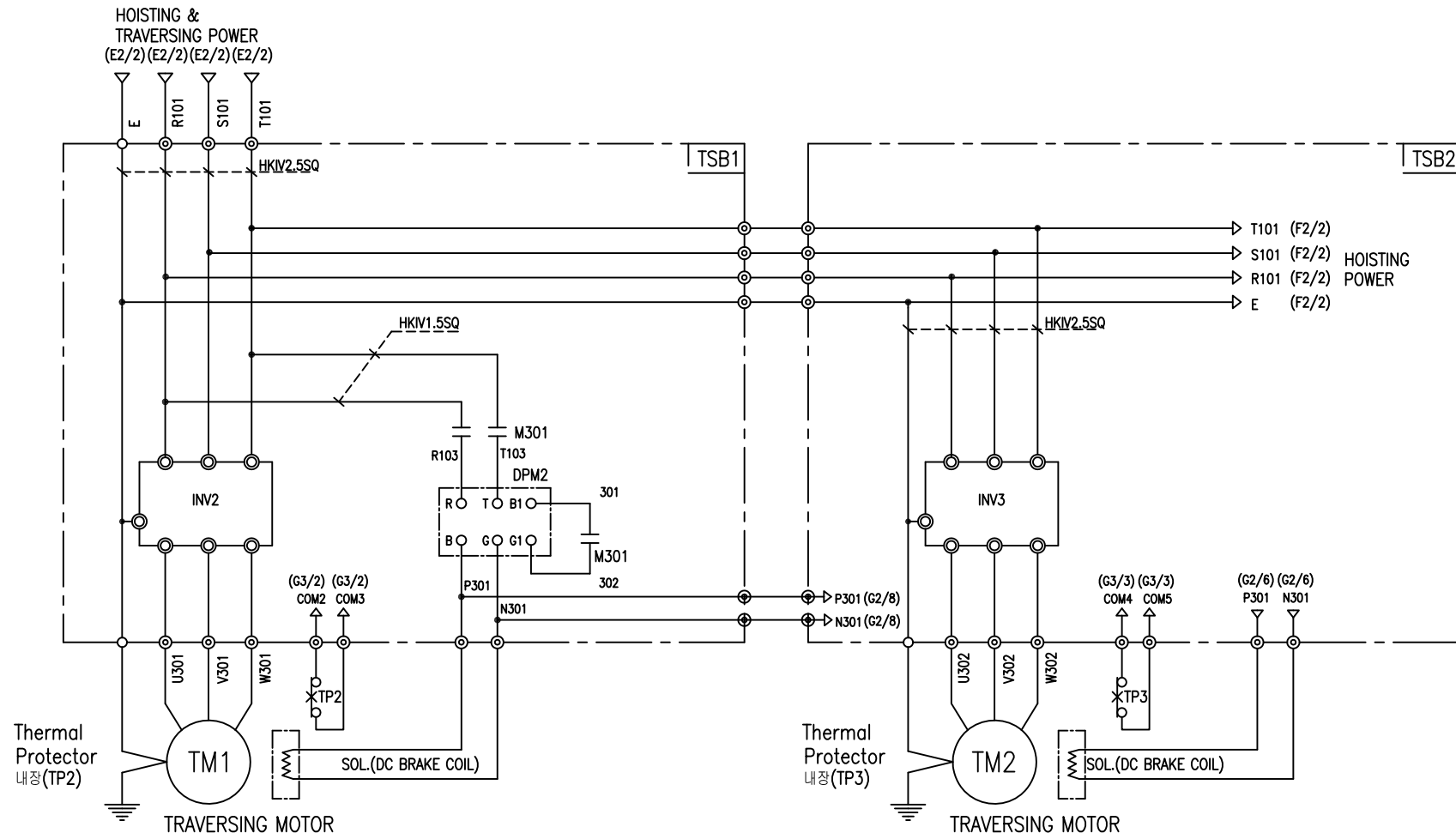

-NOTE-
 1. ---- : MARKER OWNER SCOPE
 2. —X— : Mechanical Interlock

TITLE CONNECTION DIAGRAM				PROJECTION 	
WORK NO 610	WORK NAME EDAM			SCALE	Q' TY
220V, 380V, 440V, 460V, 480V					
DRAWN LEE.G.H	CHECKED	REVIEWED	APPROVED	MODEL EDAM	CODE NO
2018.03.08				CODE_NO	
LK L K HOIST CO., LTD.					

SPECIFICATION	MAGNET CONTACT	SILICON RECTIFIER					Thermal Protector	HOIST MOTOR
SYMBOLS	M301, M302	DPM2					TP2, TP3	TM
DESCRIPTION	DMC12b	AC220V	AC380V	AC440V	AC460V	AC480V	17AM032	0.75Kw * 4P
		DC99V	DC171V	DC198V	DC207V	DC216V		0.4Kw * 6P
MAKER	DONG-A	LK					Texas Instruments	LK

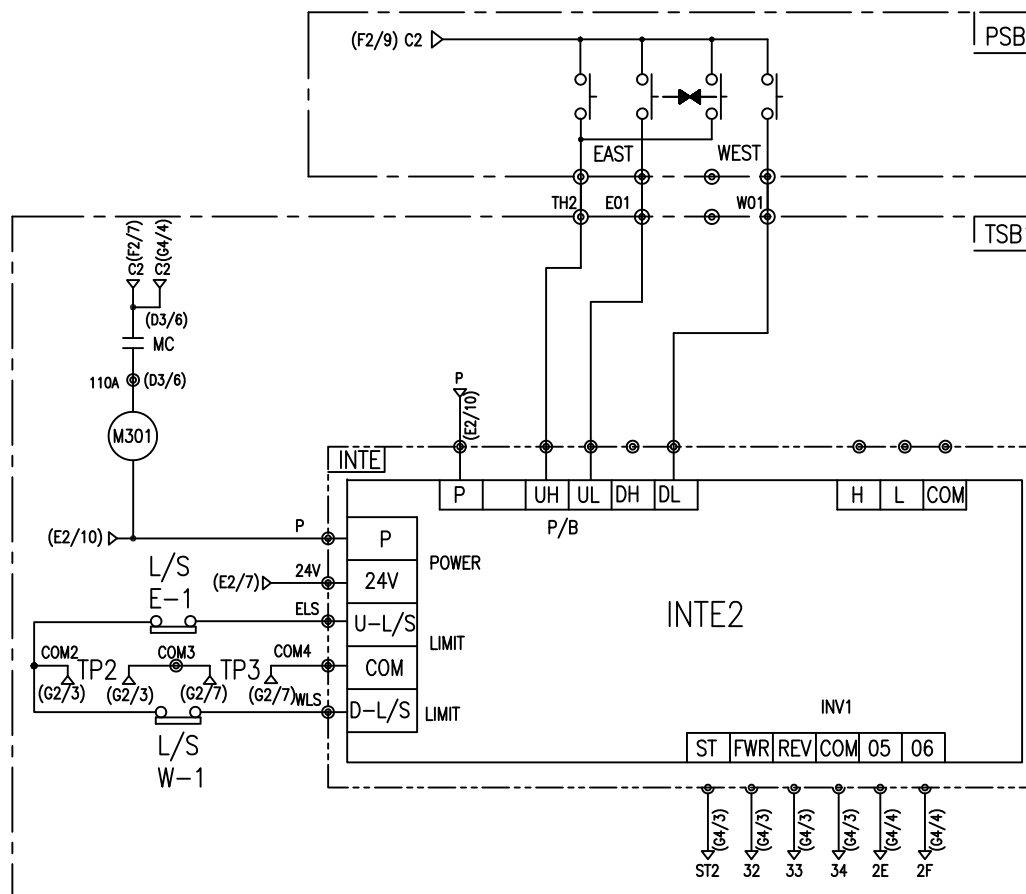

TITLE				(D1/6) PROJECTION	
INVERTER CONTROL CIRCUIT DIAGRAM					
WORK NO	WORK NAME			SCALE	Q' TY
611	TRAVERSING			1/1	1
220V, 380V, 440V, 460V, 480V					
DRAWN	CHECKED	REVIEWED	APPROVED	MODEL	EDAM
LEE.G.H				CODE NO	
2018.03.08					

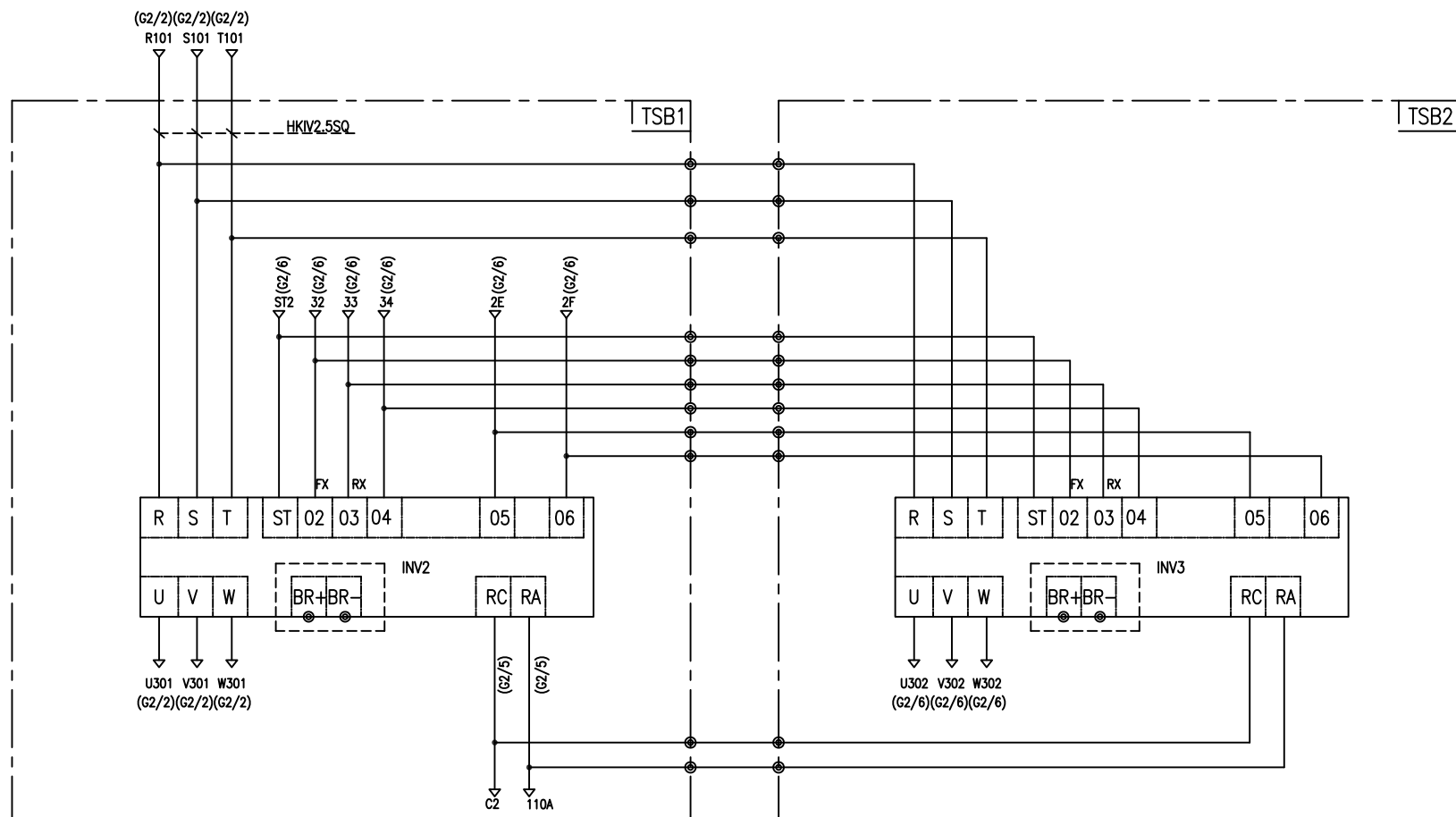

—NOTE—

1. - - - - : OPTION SCOPE

SPECIFICATION	INVERTER	BRAKING RESISTOR
SYMBOLS	INV2, INV3	BR
DESCRIPTION	0.75KW	80W 750 OHM
MAKER	ROCKWELL or LS	-

TITLE				PROJECTION	
INVERTER CONTROL CIRCUIT DIAGRAM					
WORK NO.	WORK NAME			SCALE	Q' TY
612	TRAVERSING			1/1	1
220V, 380V, 440V, 460V, 480V					
DRAWN	CHECKED	REVIEWED	APPROVED	MODEL	EDAM
LEE.G.H				CODE NO	
2018.03.08					

SCHEDULE OF TECHNICAL DATA

1. SERVICE	HOISTING
2. MANUFACTURE	LK HOIST CO. LTD
3. MOTOR MODEL NO	3.5 - 4 - 22
4. RATED POWER	3.5 KW × 4 P
5. RATED VOLTAGE AND FREQUENCY	220 V 60HZ
6. MOTOR TYPE	SQUIRREL CAGE ROTOR TYPE
7. RATING	30 MIN
8. LOCATION	IN-DOOR , OUTDOOR
9. INSULATION CLASS	B
10. DESIGN TEMPERATURE RISE (BY RESISTANCE)	80℃
11. FULL LOAD SPEED	1740 RPM
12. FULL LOAD CURRENT	17.2 A
13. STARTING CURRENT AT RATED VOLTAGE	85.1 A
14. MINIMUM STARTING VOLTAGE	198 V
15. EFFICIENCY AT 100% RATED LOAD	73.5 %
16. POWER FACTOR AT 100% RATED LOAD	72.7 %
17. STARTING TORQUE	240 %
18. TYPE OF ENCLOSURE	전폐형(IP-54)
19. TYPE OF BEARING	PL : 6205DD OPL : 6008ZZ
20. MOUNTING	VERTICAL
21. MAXIMUM AMBIENT TEMPURE	40℃
22. BEARING LUBRICATION	GREASE
23. STARTING METHOD	FULL VOLTAGE

SCHEDULE OF TECHNICAL DATA

1. SERVICE	TRAVERSING
2. MANUFACTURE	LK HOIST CO. LTD
3. MOTOR MODEL NO	0.75 - 4 - 22
4. RATED POWER	0.75 KW × 4 P
5. RATED VOLTAGE AND FREQUENCY	220 V 60HZ
6. MOTOR TYPE	SQUIRREL CAGE ROTOR TYPE
7. RATING	15 MIN
8. LOCATION	OUTDOOR
9. INSULATION CLASS	B
10. DESIGN TEMPERATURE RISE (BY RESISTANCE)	100℃
11. FULL LOAD SPEED	1670 RPM
12. FULL LOAD CURRENT	4.8 A
13. STARTING CURRENT AT RATED VOLTAGE	26.4 A
14. MINIMUM STARTING VOLTAGE	198 V
15. EFFICIENCY AT 100% RATED LOAD	65 %
16. POWER FACTOR AT 100% RATED LOAD	63 %
17. STARTING TORQUE	250 %
18. TYPE OF ENCLOSURE	전폐형
19. TYPE OF BEARING	PL : 6008DD OPL : 6207ZZ
20. MOUNTING	VERTICAL
21. MAXIMUM AMBIENT TEMPURE	40℃
22. BEARING LUBRICATION	GREASE
23. STARTING METHOD	FULL VOLTAGE

SCHEDULE OF TECHNICAL DATA

1. SERVICE	TRAVERSING
2. MANUFACTURE	LK HOIST CO. LTD
3. MOTOR MODEL NO	0.4 - 6 - 22
4. RATED POWER	0.4 KW × 6 P
5. RATED VOLTAGE AND FREQUENCY	220 V 60HZ
6. ROTOR TYPE	SQUIRREL CAGE ROTOR TYPE
7. RATING	15 MIN
8. LOCATION	OUTDOOR
9. INSULATION CLASS	B
10. DESIGN TEMPERATURE RISE (BY RESISTANCE)	100℃
11. FULL LOAD SPEED	1140 RPM
12. FULL LOAD CURRENT	3.2 A
13. STARTING CURRENT AT RATED VOLTAGE	17.5 A
14. MINIMUM STARTING VOLTAGE	198 V
15. EFFICIENCY AT 100% RATED LOAD	65 %
16. POWER FACTOR AT 100% RATED LOAD	63 %
17. STARTING TORQUE	250 %
18. TYPE OF ENCLOSURE	전폐형
19. TYPE OF BEARING	PL : 6008DD OPL : 6207ZZ
20. MOUNTING	VERTICAL
21. MAXIMUM AMBIENT TEMPERATURE	40℃
22. BEARING LUBRICATION	GREASE
23. STARTING METHOD	FULL VOLTAGE