

L K HOIST

ON GMD

NO	DESCRIPTION	SIZE	MAT' L	Q' TY	WT (kg)	REMARKS

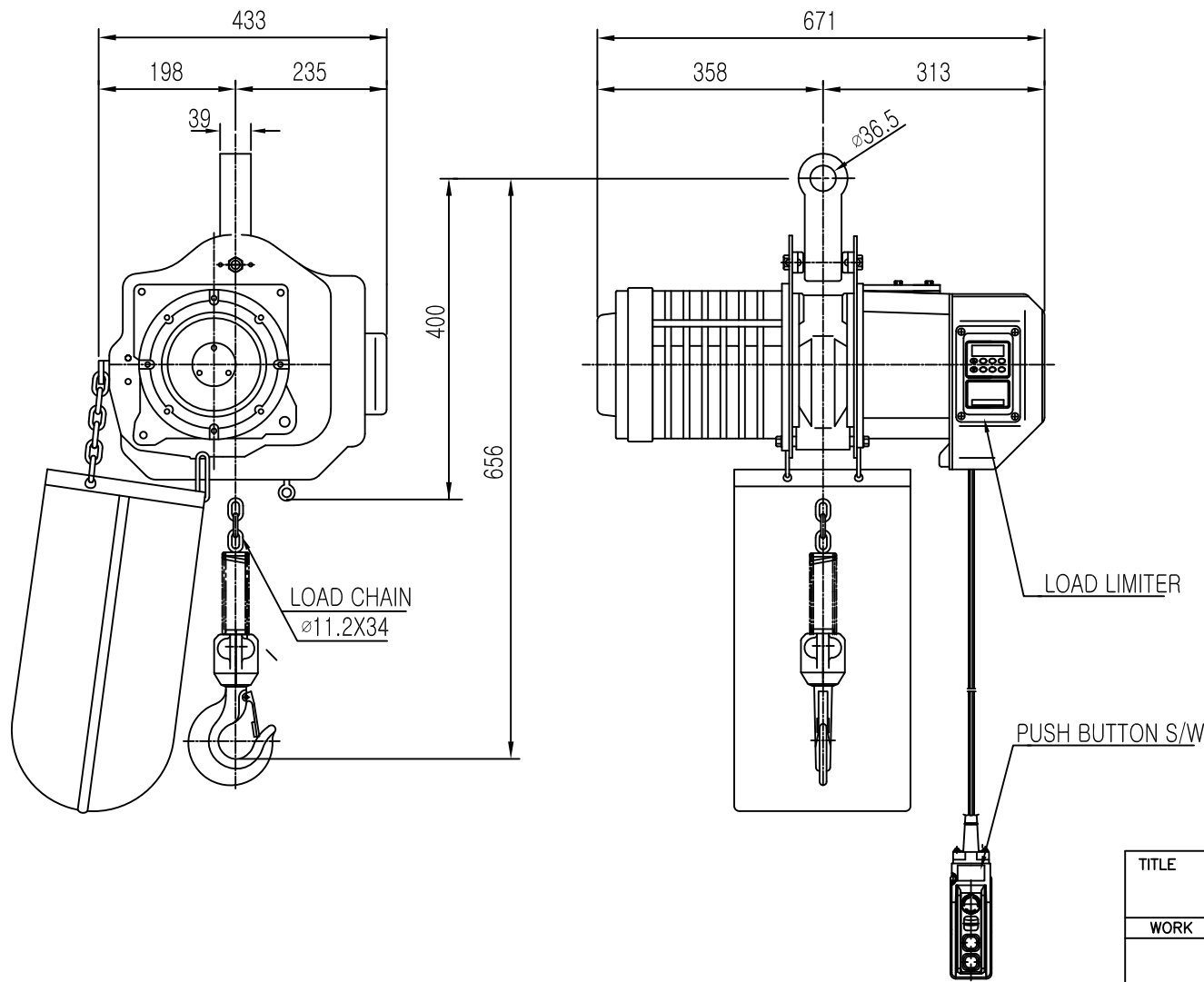

SPECIFICATION	
RATED LOAD	2 TON
TESTING LOAD	2.5 TON
LIFTING HEIGHT	50 M
HOISTING	SPEED 6.5 M/MIN
	MOTOR 3.5 KW x 1 SET
TRAVERSING	SPEED - M/MIN
	MOTOR - KW x - SET
POWER SUPPLY	AC220,380,440,460,480V x 3øx60Hz
OPERATING METHOD	P.B type ON . FL
LOAD CHAIN	ø11.2 x 34 (1 FALL)
WIEGHT	250 KG

NOTE)
 1) 점검 설비를 갖출것.
 2) 인허가 서류를 완성검사시 제출할것.

TITLE				PROJECTION	
DALG-2S ELECTRIC CHAIN HOIST					
WORK NO	WORK NAME			SCALE	Q' TY
	CONNECTOR TYPE			N S	1
DRAWN	CHECKED	REVIEWED	APPROVED	DRAWING NO	
김 창 기					
2010.07.27					

REV.NO	DATE	REVISION	DESCRIPTION	DRAWN	CHECKED	APPROVED

L K HOIST

ON 3MD

NO	DESCRIPTION	SIZE	MAT' L	Q' TY	WT (kg)	REMARKS

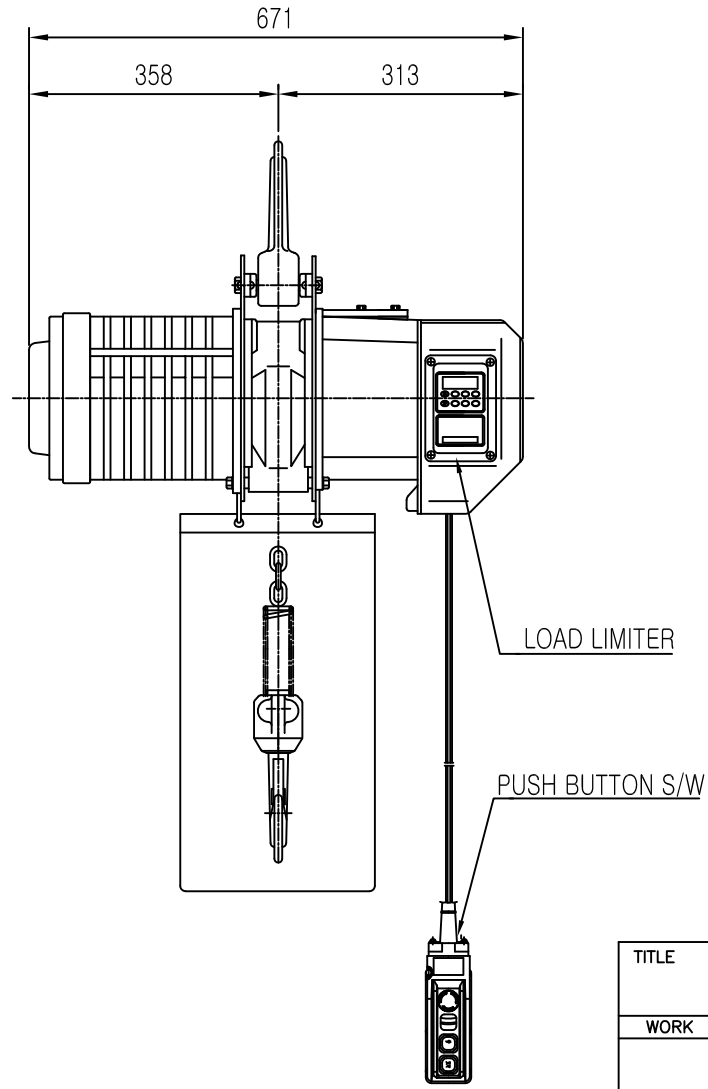
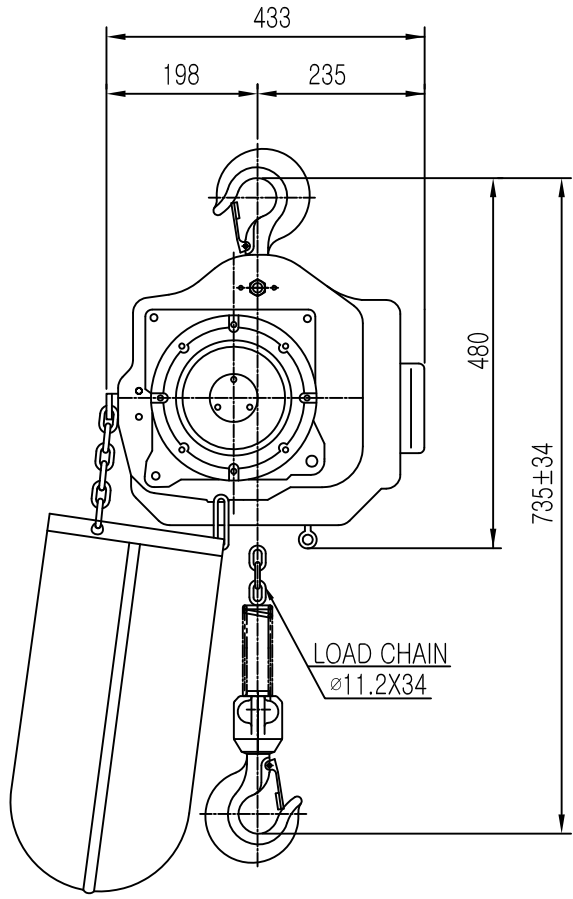

SPECIFICATION	
RATED LOAD	2 TON
TESTING LOAD	2.5 TON
LIFTING HEIGHT	50 M
HOISTING	SPEED 6.5 M/MIN
	MOTOR 3.5 KW x 1 SET
TRAVERSING	SPEED - M/MIN
	MOTOR - KW x - SET
POWER SUPPLY	AC220,380,440,460,480V x 3øx60Hz
OPERATING METHOD	P.B type ON . FL
LOAD CHAIN	ø11.2 x 34 (1 FALL)
WIEGHT	250 KG

- NOTE)
 1) 점검 설비를 갖출것.
 2) 인허가 서류를 완성검사시 제출할것.

TITLE				PROJECTION	
DALG-2S ELECTRIC CHAIN HOIST					
WORK NO	WORK NAME			SCALE	Q' TY
	HOOK TYPE			N S	1
DRAWN	CHECKED	REVIEWED	APPROVED	DRAWING NO	
김 창 기					
2010.07.27					

REV.NO	DATE	REVISION	DESCRIPTION	DRAWN	CHECKED	APPROVED