

ON 5MD

L K HOIST

NO	DESCRIPTION	SIZE	MAT' L	Q' TY	WT (kg)	REMARKS

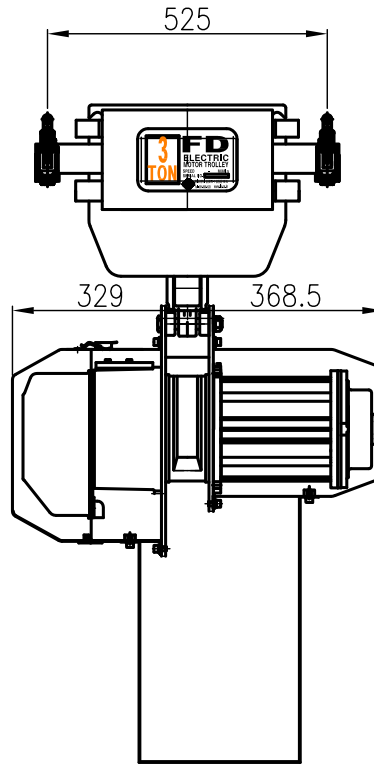
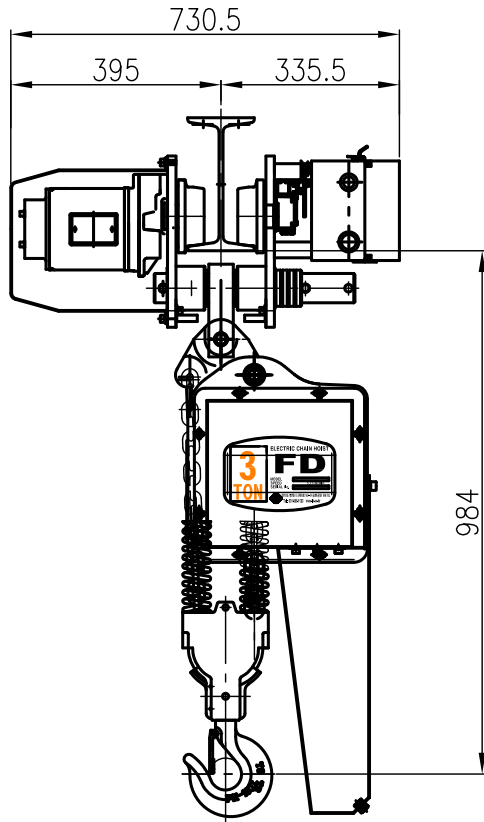

SPECIFICATION		
HOISTING LOAD	3.0 TON	
TESTING LOAD	3.75 TON	
LIFTING HEIGHT	20 M	
HOISTING SPEED	5.15 M/MIN	
HOISTING MOTOR	3.5 KW x 4p	
TRAVERSING SPEED	16 M/MIN	11 M/MIN
TRAVERSING MOTOR	0.75 KW x 4p	0.4 KW x 6p
POWER SUPPLY	AC 220,380,440,460,480V x 3ø x 60 Hz	
OPERATING METHOD	P.B type ON . FL	
WEIGHT	305 KG	
I-BEAM SIZE	125 MM	

적용 I-BEAM)

- 1) 지점간 거리: I-200X100X7/10 - 2.0M
- 2) 지점간거리 : I-250X125X7.5/12.5-3.8M
- 3) 지점간거리 : I-300X150X10/18.5-6.3M
- 4) 지점간거리 : I-450X175X13/26-11.5M

적용 H-BEAM)

- 1) 지점간 거리: I-200X100X5.5/8 - 1.7M
- 2) 지점간거리 : I-250X125X6/9-3.0M
- 3) 지점간거리 : I-300X150X6.5/9-4.2M
- 4) 지점간거리 : I-450X200X9/14-6.5M

REV.NO	DATE	REVISION	DESCRIPTION	DRAWN	CHECKED	APPROVED

TITLE				PROJECTION	
ELECTRIC CHAIN HOIST					
LK-FDAM-3W				SCALE	Q' TY
				1/1	1
DRAWN	CHECKED	REVIEWED	APPROVED	DRAWING NO	
김 창 기				CODE NO	
19.07.31					
L K HOIST CO., LTD.					