

ON 3MG

# L K HOIST

| NO | DESCRIPTION | SIZE | MAT' L | Q' TY | WT (kg) | REMARKS |
|----|-------------|------|--------|-------|---------|---------|
|----|-------------|------|--------|-------|---------|---------|

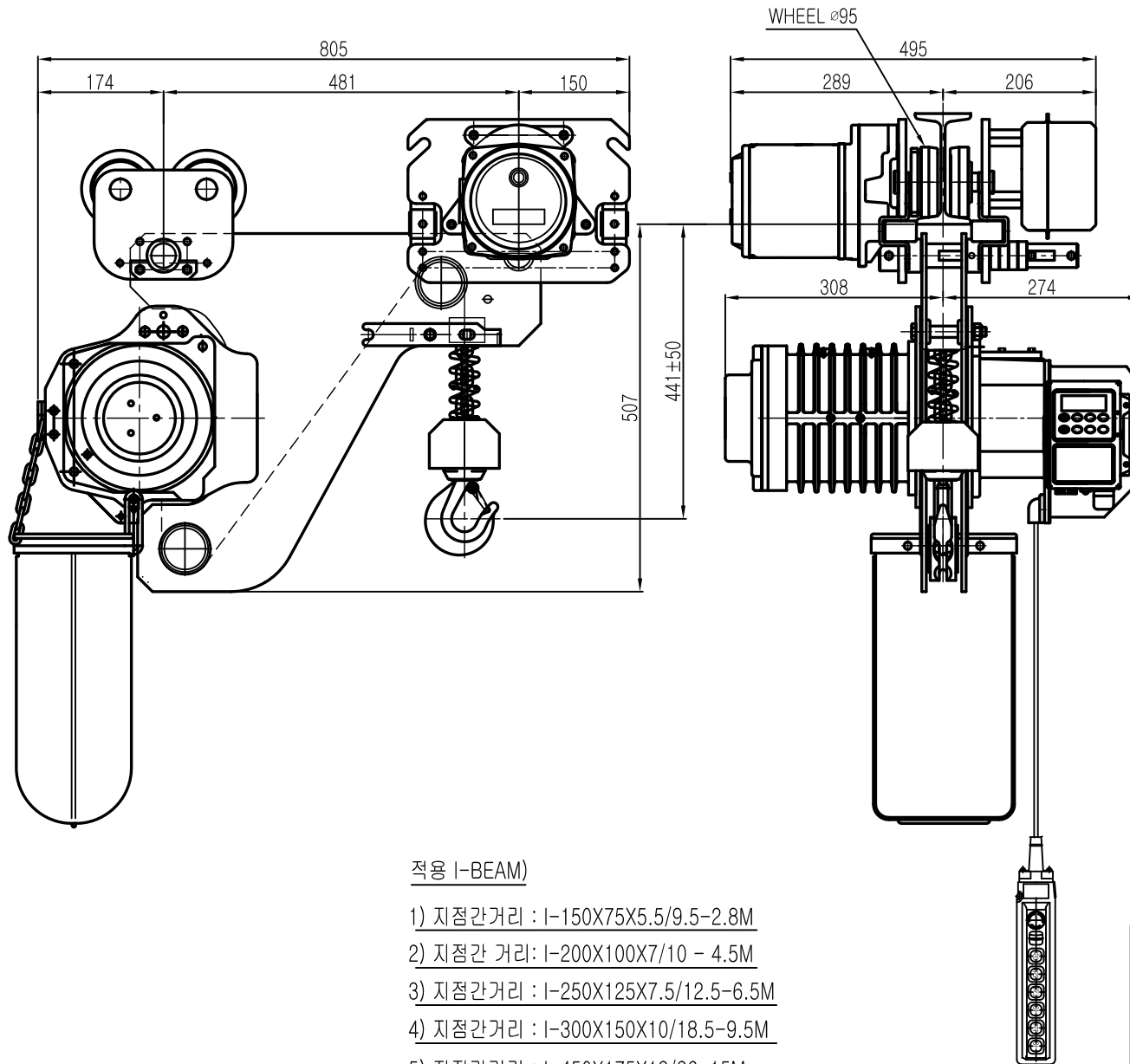

## SPECIFICATION

|                  |                                   | LK-SHDAM-1S |            |                    |
|------------------|-----------------------------------|-------------|------------|--------------------|
| RATED LOAD       | (TON)                             | 1.0         |            |                    |
| TESTING LOAD     | (TON)                             | 1.25        |            |                    |
| LIFTING HEIGHT   | (M)                               | 50          |            |                    |
| HOISTING         | SPEED (M/MIN)                     | 8.2         |            |                    |
|                  | MOTOR (KW)                        | 1.8kw x 4p  |            |                    |
| TRAVERSING       | SPEED (M/MIN)                     | 22          | 14         | 22/7               |
|                  | MOTOR (KW)                        | 0.4kw x 4p  | 0.3kw x 6p | 0.4/0.14kw x 4/12p |
| POWER SUPPLY     | AC220.380.440.460.480Vx3ø x 60 Hz |             |            |                    |
| OPERATING METHOD | P.B type ON . FL                  |             |            |                    |
| LOAD CHAIN       | ø7.1 X 21 (1FALL)                 |             |            |                    |
| WEIGHT           | (KG)                              | 205         |            |                    |
| I-BEAM 적용폭       | 75 ~ 175MM                        |             |            |                    |

### NOTE)

- 1) 점검 설비를 갖출 것
- 2) 인허가 서류를 완성검사시 제출 할 것

적용 I-BEAM)

- 1) 지점간거리 : I-150X75X5.5/9.5-2.8M
- 2) 지점간 거리: I-200X100X7/10 - 4.5M
- 3) 지점간거리 : I-250X125X7.5/12.5-6.5M
- 4) 지점간거리 : I-300X150X10/18.5-9.5M
- 5) 지점간거리 : I-450X175X13/26-15M

| TITLE      |           | ELECTRIC CHAIN HOIST |          |            | PROJECTION |  |
|------------|-----------|----------------------|----------|------------|------------|--|
| WORK NO    | WORK NAME | LK-SHDAM-1S          |          | SCALE      | Q' TY      |  |
|            |           |                      |          | N S        | 1          |  |
| DRAWN      | CHECKED   | REVIEWED             | APPROVED | DRAWING NO |            |  |
| 김 창 기      |           |                      |          | CORD NO    |            |  |
| 2010.08.01 |           |                      |          |            |            |  |



L K HOIST CO., LTD.

| REV.NO | DATE | REVISION | DESCRIPTION | DRAWN | CHECKED | APPROVED |
|--------|------|----------|-------------|-------|---------|----------|
|--------|------|----------|-------------|-------|---------|----------|

ON GMD

# L K HOIST

| NO | DESCRIPTION | SIZE | MAT L | Q' TY | WT (kg) | REMARKS |
|----|-------------|------|-------|-------|---------|---------|
|    |             |      |       |       |         |         |

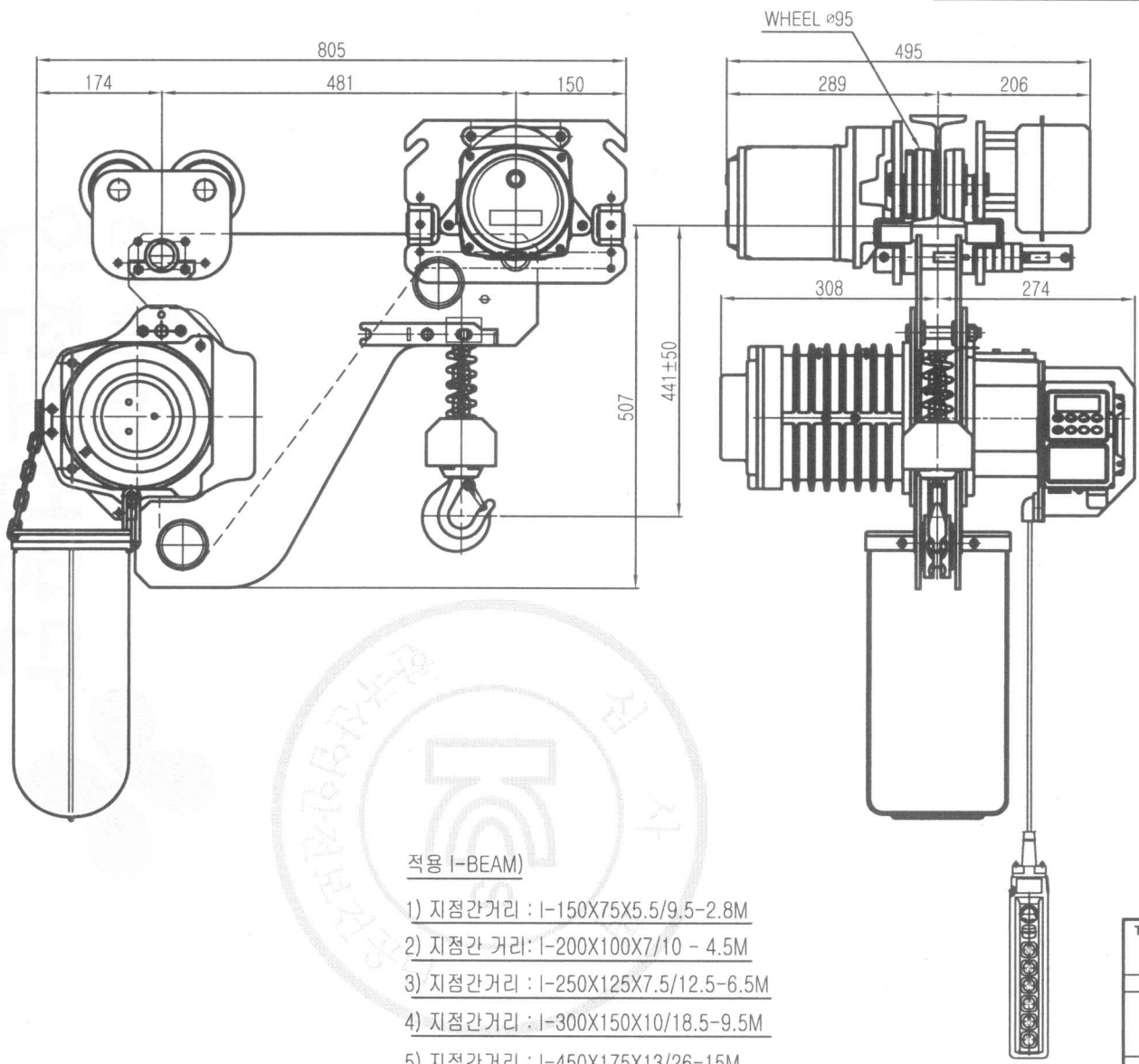

## SPECIFICATION

|                  |                                   | LK-SHDAM-1S |            |                    |
|------------------|-----------------------------------|-------------|------------|--------------------|
| RATED LOAD       | (TON)                             | 1.0         |            |                    |
| TESTING LOAD     | (TON)                             | 1.25        |            |                    |
| LIFTING HEIGHT   | (M)                               | 50          |            |                    |
| HOISTING         | SPEED (M/MIN)                     | 8.2         |            |                    |
|                  | MOTOR (KW)                        | 1.8kw x 4p  |            |                    |
| TRAVERSING       | SPEED (M/MIN)                     | 22          | 14         | 22/7               |
|                  | MOTOR (KW)                        | 0.4kw x 4p  | 0.3kw x 6p | 0.4/0.14kw x 4/12p |
| POWER SUPPLY     | AC220.380.440.460.480Vx3ø x 60 Hz |             |            |                    |
| OPERATING METHOD | P.B type ON . FL                  |             |            |                    |
| LOAD CHAIN       | ø7.1 X 21 (1FALL)                 |             |            |                    |
| WEIGHT           | (KG)                              | 205         |            |                    |
| I-BEAM 적용폭       |                                   | 75 ~ 175MM  |            |                    |

원본복제 및 배포금지

적용 I-BEAM)

- 1) 지점간거리 : I-150X75X5.5/9.5-2.8M
- 2) 지점간 거리: I-200X100X7/10 - 4.5M
- 3) 지점간거리 : I-250X125X7.5/12.5-6.5M
- 4) 지점간거리 : I-300X150X10/18.5-9.5M
- 5) 지점간거리 : I-450X175X13/26-15M

NOTE)

- 1)점검 설비를 갖출 것
- 2)인허가 서류를 완성검사시 제출 할 것

| REV.NO | DATE | REVISION | DESCRIPTION | DRAWN | CHECKED | APPROVED |
|--------|------|----------|-------------|-------|---------|----------|
|        |      |          |             |       |         |          |

| TITLE                |             |          |          | PROJECTION |       |
|----------------------|-------------|----------|----------|------------|-------|
| ELECTRIC CHAIN HOIST |             |          |          |            |       |
| WORK NO              | WORK NAME   |          |          | SCALE      | Q' TY |
|                      | LK-SHDAM-1S |          |          | N S        | 1     |
| DRAWN                | CHECKED     | REVIEWED | APPROVED | DRAWING NO |       |
| 김 창 기                |             |          |          | CORD NO    |       |
| 2010.08.01           |             |          |          |            |       |
| L K HOIST CO., LTD.  |             |          |          |            |       |