

ON 9MD

L K HOIST

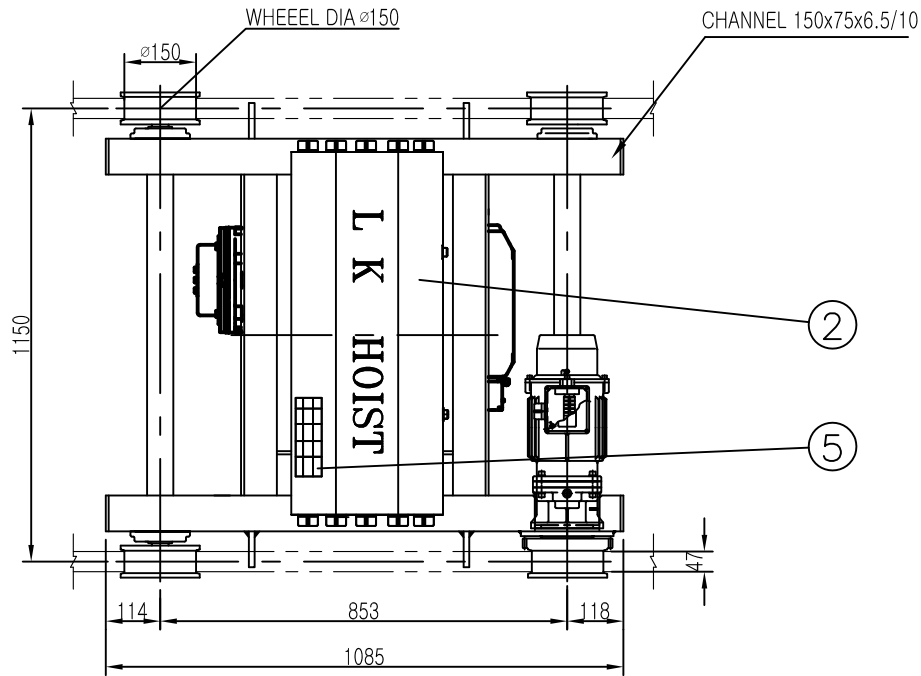

NO	DESCRIPTION	SIZE	MAT'	REMARKS
1	HOISTING MOTOR ASS'Y		1	
2	HOISTING CONTROL ASS'Y		1	
3	GEARED MOTOR ASS'Y		1	
4	BOTTOM HOOK ASS'Y		1	
5	NAME PLATE		1	
6	LOAD LIMITER		1	

SPECIFICATION		
RATED LOAD	5.0	TON
TESTING LOAD	6.25	TON
LIFTING HEIGHT	30	M
	SPEED	MOTOR
HOISTING	3.25/1.0 m/min	4.4/2.2KW(2P/6P)
	24m/min	0.75KW(4P)
TRAVERSING	16m/min	0.5KW(6P)
	24/8m/min	0.75/0.25KW *4/12P
	17/5.4m/min	0.75/0.25KW *4/12P
POWER SUPPLY	AC220,380,440,460,480V x 3φ x 60 Hz	
OPERATING METHOD	P.B type ON . FL	
WIEGHT	484KG	
RAIL	15Kg/m	
RAIL gauge	1150MM	
LOAD CHAIN	11.2 X 34(2줄)	

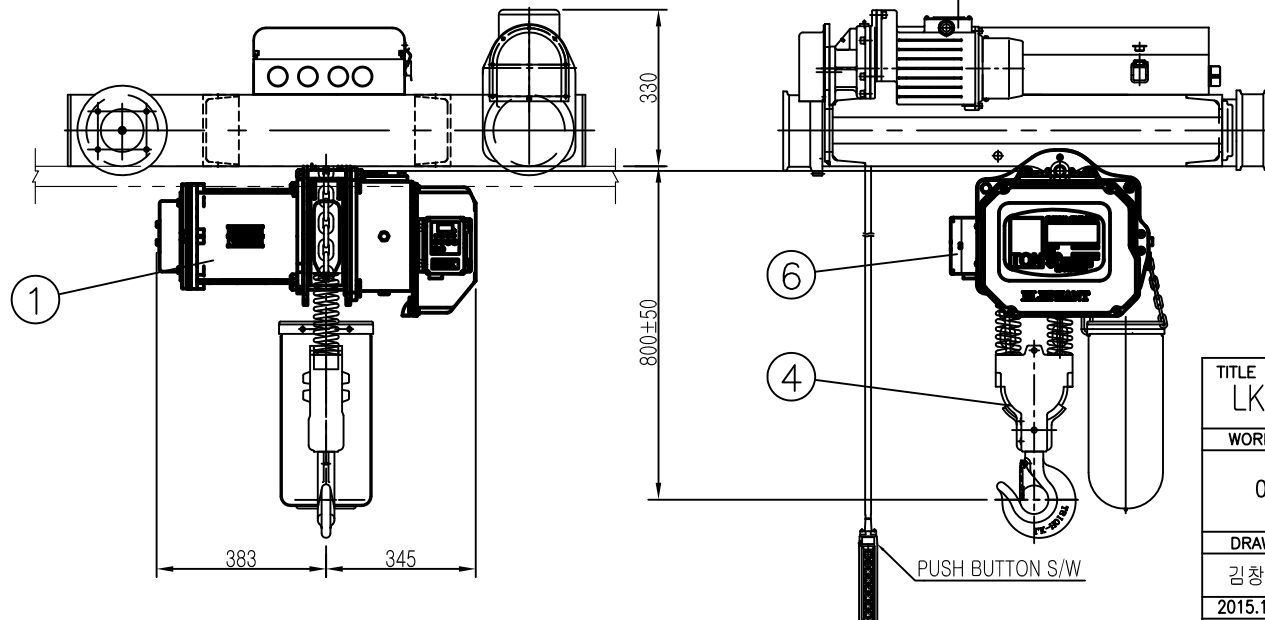

NOTE)

1. 점검 설비를 갖출 것.
2. 인허가 서류를 완성 검사시 제출 할 것.

TITLE					PROJECTION	
LK-DBDS-5W ELECTRIC CHAIN HOIST						
WORK NO	WORK NAME				SCALE	Q' TY
000	LK-DBDS-5W				N S	1
HOIST ASS'Y						
DRAWN	CHECKED	REVIEWED	APPROVED	MODEL		
김창기				CODE NO		
2015.11.05						
L K HOIST CO., LTD.						